



Installation and Operation Instructions

P/N 900301-01 REV. D 04/2017

Ce manuel est disponible en français, simplement en faire la demande. Numéro de la pièce 900301-03.



Marin™ B-Vent Gas Fireplaces

Models

Marin40STTMN

INSTALLER: Leave this manual with the appliance.
CONSUMER: Retain this manual for future reference.

Installateur : Laissez cette notice avec l'appareil.
Consommateur : Conservez cette notice pour consultation ultérieure.

Decorative Product: Not for use as a heating appliance.

NOTICE: Fireplace is not to be operated by a thermostat.

⚠ WARNING:

FIRE OR EXPLOSION HAZARD

Failure to follow safety warnings exactly could result in serious injury, death, or property damage.

- Do not store or use gasoline or other flammable vapors and liquids in the vicinity of this or any other appliance.
- **WHAT TO DO IF YOU SMELL GAS**
 - Do not try to light any appliance.
 - Do not touch any electrical switch; do not use any phone in your building.
 - Leave the building immediately.
 - Immediately call your gas supplier from a neighbor's phone. Follow the gas supplier's instructions.
 - If you cannot reach your gas supplier, call the fire department.
- Installation and service must be performed by a qualified installer, service agency or the gas supplier.

⚠ AVERTISSEMENT:

RISQUÉ D'INCENDIE OU D'EXPLOSION

Le non-respect Des avertissements de sécurité pourrait d'entraîner des blessures graves, la mort ou des dommages matériels.

- Ne pas entreposer ni utiliser d'essence ni d'autres vapeurs ou liquides inflammables dans le voisinage de cet appareil ou de tout autre appareil.
- **QUE FAIRE SI VOUS SENTEZ UNE ODEUR DE GAZ:**
 - Ne pas tenter d'allumer d'appareil.
 - Ne touchez à aucun interrupteur. Ne pas vous servir des téléphones se trouvant dans le bâtiment où vous trouvez.
 - Sortez immédiatement de bâtiment.
 - Appelez immédiatement votre fournisseur de gaz depuis un voisin. Suivez les instructions du fournisseur.
 - Si vous ne pouvez rejoindre le fournisseur de gaz, appelez le service des incendies.
- L'installation et l'entretien doivent être assurés par un installateur ou un service d'entretien qualifié ou par le fournisseur de gaz.

SAFETY AND YOUR FIREPLACE

See attached color flyer for proper color representation



DANGER



HOT GLASS WILL CAUSE BURNS.
DO NOT TOUCH GLASS UNTIL COOLED.
NEVER ALLOW CHILDREN TO TOUCH GLASS.

A barrier designed to reduce the risk of burns from the hot viewing glass is provided with this appliance and shall be installed for the protection of children and other at-risk individuals.

Voir ci-joint tract pour une bonne représentation de la couleur



DANGER



VITRE CHAUDE RISQUE DE BRÛLURES.
NE TOUCHEZ PAS UNE VITRE NON REFROIDIE.
NE LAISSEZ JAMAIS UN ENFANT DE TOUCHER LA VITRE.

L'écran pare-étincelles fourni avec ce foyer réduit le risque de brûlure en cas de contact accidentel avec la vitre chaude et doit être installé pour la protection Des enfants et Des personnes à risques.

Vea el volante adjunto para la representación de color adecuado



PELIGRO



EL VIDRIO CALIENTE CAUSARÁ QUEMADURAS.
USTED DEBE NUNCA TOCAR EL VIDRIO CALIENTE.
LOS NIÑOS DEBEN NUNCA TOCAR EL VIDRIO.

Una barrera diseñada para reducir el riesgo de quemaduras desde la mirilla (vidrio) caliente es proveida con este aparato y deberá instalarse para la protección de los niños y otros individuos en riesgo.

Safety and Your Fireplace

**All parts of your
IHP fireplace get
EXTREMELY HOT!**

- To prevent severe burns and injuries, do Not remove the barrier on the appliance which prevents direct contact with the glass.
- Follow the safety instructions below and be sure everyone in your household understands this burn hazard:
 - **The surfaces on your fireplace get EXTREMELY HOT!**
 - **The glass on the front of the fireplace reaches EXTREMELY HIGH temperatures and can cause severe burns if touched.**
 - **Keep children away from an operating fireplace. Closely supervise children in any room where a fireplace is operating to prevent contact with glass.**
 - **Keep clothing, furniture, gasoline, and other flammable liquids away from the fireplace.**
 - **Even after the gas is turned off, fireplace surfaces remain extremely hot.**
- Be sure to attach the enclosed **Safety-in-Operation Warnings** where you turn on your fireplace, to help remind everyone of the dangers associated with high temperatures (**Page 24**).
- Read **Important Safety Information** (**Page 28**).



La sécurité et votre foyer

**Toutes les parties de votre
foyer IHP deviennent
EXTRÊMEMENT CHAUDES !**

- Afin d'éviter les brûlures graves ou les blessures, ne pas retirer l'écran de protection de la foyer qui empêche tout contact direct avec la vitre.
- Suivez les instructions de sécurité ci-dessous et veillez à ce que tous les membres de votre famille soient conscients du danger de brûlure encouru :
 - **Les surfaces de votre foyer deviennent EXTRÊMEMENT CHAUDES !**
 - **La vitre située à l'avant du foyer atteint des températures EXTRÊMEMENT ÉLEVÉES et peut causer de graves blessures en cas de contact.**
 - **Tenez les enfants à l'écart du foyer lorsqu'il fonctionne. Surveillez attentivement les enfants dans les pièces où un foyer est utilisé afin d'éviter qu'ils ne soient en contact avec la vitre.**
 - **Tenez tous les vêtements, les meubles, l'essence et tout autre liquide inflammable à l'écart du foyer.**
 - **Même après fermeture du gaz, les surfaces du foyer restent extrêmement chaudes.**
- Veillez à coller les **Étiquettes de mise en garde relatives à la sécurité d'utilisation** à l'endroit où vous utilisez le foyer, pour rappeler à tous les utilisateurs les dangers liés aux températures élevées (**Page 24**).
- Lisez **L'information de sûreté importante** (**Page 28**).



Seguridad y su chimenea

**¡Todas las partes de la
chimenea IHP se ponen
MUY CALIENTES!**

- Para evitar quemaduras y lesiones graves, no quite el protector de malla o guardia de seguridad que evita el contacto directo con el vidrio.
- Siga las instrucciones de seguridad a continuación y asegúrese de que todos en su hogar sepan acerca de este peligro de quemadura:
 - **¡Las superficies de la chimenea se ponen MUY CALIENTES!**
 - **El vidrio delante de la chimenea alcanza temperaturas EXTREMADAMENTE ALTAS y puede causar quemaduras graves si se toca.**
 - **Mantenga a los niños alejados de la chimenea en funcionamiento. Supervise en forma cercana a los niños en cualquier cuarto donde haya una chimenea funcionando para impedir el contacto con el vidrio.**
 - **Mantenga la ropa, mobiliario, gasolina y otros líquidos inflamables alejados de la chimenea.**
 - **Aún después de haber apagado el gas, las superficies de la chimenea permanecen extremadamente calientes.**
- Asegúrese de colocar las **Etiquetas de advertencia de seguridad de operación** en el lugar donde enciende la chimenea, para que todos recuerden los peligros asociados con las altas temperaturas (**Página 28**).
- Lea **Información importante de seguridad** (**Página 28**).

TABLE OF CONTENTS

Safety and Your Fireplace.....	Page 2
Packaging	Page 4
Introduction	Page 4
General Information	Page 4
Requirements for the Commonwealth of Massachusetts	Page 6
Cold Climate Insulation	Page 7
Location	Page 7
Vent Termination Clearances	Page 8
Appliance and Vent Clearances	Page 9
Pre-Installation Steps.....	Page 10
Typical Installation Sequence	Page 10
Step 1. Framing.....	Page 11
Fireplace Specifications	Page 12
Step 2. Routing Gas Line	Page 13
Step 3. Install The Venting System ...	Page 13
Step 4. Field Wiring.....	Page 14
Step 5. Connecting Gas Line	Page 15
Step 6. Outside Air Kit.....	Page 16
Step 7. Verifying Appliance Operation	Page 17
Step 8. Installing Logs	Page 18
Step 9. Remove/Install Glass Door .	Page 21
Step 10. Burner Adjustments	Page 21
Step 11. Hood Installation.....	Page 22
Finishing Requirements	Page 22
Step 12. Spillage Test/Safety Switch.	Page 23
Step 13. Installer - Attaching Safety-	
in-Operation Warnings.....	Page 24
Gas Conversion Kits	Page 25
Operation/Care of Your Appliance	Page 27
Gas Controls Access	Page 27
Important Safety Information	Page 28
Homeowner- Attaching Safety-	
in-Operation Warnings.....	Page 29
Maintenance.....	Page 34
Front Glass Enclosure Panel, Removal and Installation.....	Page 35
Install Vermiculite, Embers and Logs	Page 36
Burner Flame Appearance/Sooting ...	Page 39
Burner Flame Adjustments	Page 40
Millivolt Appliance Checkout	Page 40
Wiring Diagrams	Page 41
Accessory Components	Page 42
Maintenance Schedule	Page 44
Lighting Instructions – Millivolt	Page 45
Troubleshooting Guide – Millivolt.....	Page 47
Replacement Parts List	Page 48
Warranty	Page 51

Please read and understand these instructions before beginning your installation.



We recommend that our gas hearth products be installed and serviced by professionals who are certified in the U.S. by the National Fireplace Institute® (NFI) as NFI Gas Specialists.

PACKAGING

The assembled vented gas fireplace is packaged with:

- 1 - One log set located within the firebox.
- 2 - One plastic bag containing the literature package, which consists of Installation and Operations manual (this manual), Safety Flyer, Glass and Barrier Flyer and Safety-in-Operation Warning Labels, 8 nailing flanges; plastic bag is located on top of the fireplace.
- 3 - Two hoods (installed).
- 4 - One plastic bag of glowing embers, one plastic bag of decorative volcanic stone and one bag of vermiculite is located in the bottom compartment.
- 5 - Barrier
- 6 - Front Face Assembly

NOTE:

- If the barrier becomes damaged, the barrier shall be replaced with the manufacturer's barrier for this appliance.
- For use with barrier(s) Part No(s). J7420.

INTRODUCTION

The *Millivolt* appliances have a millivolt gas control valve with piezo ignition system. If any optional accessories that will require electrical power are to be installed, the electrical power must be provided at the time of appliance installation.

These vented gas fireplaces are designed for residential applications. They must be installed with approved type-B, 6" double wall vent pipe systems routed to the outside atmosphere.

GENERAL INFORMATION

WARNING

B-Vent appliances are not designed to operate in negatively pressured environments (pressure within the home is less than pressures outside). Significant negatively pressured environments caused by weather, home design, or other devices may impact the operation of these appliances. Negative pressures may result in poor flame appearance, sooting, damage to property and/or severe personal injury. Do not operate these appliances in negatively pressured environments.

WARNING

Young children should be carefully supervised when they are in the same room as the appliance. Toddlers, young children and others may be susceptible to accidental contact burns. A physical barrier is recommended if there are at risk individuals in the house. To restrict access to a fireplace or stove, install an adjustable safety gate to keep toddlers, young children and other at risk individuals out of the room and away from hot surfaces.

AVERTISSEMENT

Les jeunes enfants devraient être surveillés étroitement lorsqu'ils se trouvent dans la même pièce que l'appareil. Les tout petits, les jeunes enfants ou les adultes peuvent subir des brûlures s'ils viennent en contact avec la surface chaude. Il est recommandé d'installer une barrière physique si des personnes à risques habitent la maison. Pour empêcher l'accès à un foyer ou à un poêle, installez une barrière de sécurité; cette mesure empêchera les tout petits, les jeunes enfants et toute autre personne à risque d'avoir accès à la pièce et aux surfaces chaudes.

Children and adults should be alerted to the hazards of high surface temperature and should stay away to avoid burns or clothing ignition.

Les enfants et les adultes devraient être informés des dangers que posent les températures de surface élevées et se tenir à distance afin d'éviter des brûlures ou que leurs vêtements ne s'enflamment.

DO NOT ATTEMPT TO ALTER OR MODIFY THE CONSTRUCTION OF THE APPLIANCE OR ITS COMPONENTS. ANY MODIFICATION OR ALTERATION MAY VOID THE WARRANTY, CERTIFICATION AND LISTINGS OF THIS UNIT.

! WARNING

Improper installation, adjustment, alteration, service or maintenance can cause injury or property damage. Refer to this manual. For assistance or additional information consult a qualified installer, service agency or the gas supplier.

! WARNING

Failure to comply with these installation instructions will result in an improperly installed and operating appliance, voiding its warranty. Any change to this appliance and/or its operating controls is dangerous.

! WARNING

Clothing or other flammable material should not be placed on or near the appliance.

! AVERTISSEMENT

On ne devrait pas placer de vêtements ni d'autres matières inflammables sur l'appareil ni à proximité.

! WARNING

Any safety screen, guard, or barrier removed for servicing an appliance must be replaced prior to operating the appliance.

! AVERTISSEMENT

Tout écran ou protecteur retiré pour permettre l'entretien de l'appareil doit être remis en place avant de mettre l'appareil en marche.

! WARNING

THIS APPLIANCE MAY ONLY BE FITTED WITH DOORS CERTIFIED FOR USE WITH THE APPLIANCE.

! WARNING

Failure to position the parts in accordance with these diagrams or failure to use only parts specifically approved with this appliance may result in property damage or personal injury.

! AVERTISSEMENT

Risque de dommages ou de blessures si les pièces ne sont pas installées conformément à ces schémas et ou si des pièces autres que celles spécifiquement approuvées avec cet appareil sont utilisées.

Installation and repair should be done by a qualified service person. The appliance should be inspected before use and at least annually by a professional service person. More frequent cleaning may be required due to excessive lint from carpeting, bedding material, etcetera. It is imperative that control compartments, burners and circulating air passageways of the appliance be kept clean.

L'installation et la réparation devrait être confiées à un technicien qualifié. L'appareil devrait faire l'objet d'une inspection par un technicien professionnel avant d'être utilisé et au moins une fois l'an par la suite. Des nettoyages plus fréquents peuvent être nécessaires si les tapis, la literie, et cetera produisent une quantité importante de poussière. Il est essentiel que les compartiments abritant les commandes, les brûleurs et les conduits de circulation d'air de l'appareil soient tenus propres.

Do not use this appliance if any part has been under water. Immediately call a qualified service technician to inspect the appliance and to replace any part of the control system and any gas control which has been under water.

Ne pas utiliser cet appareil s'il a été plongé, même partiellement, dans l'eau. Appeler un technicien qualifié pour inspecter l'appareil et remplacer toute partie du système de commande et toute commande qui a été plongée dans l'eau.

Only trim kit(s) supplied by the manufacturer shall be used in the installation of this appliance.

Seules les trousse de garniture fournies par le fabricant doivent être utilisées pour l'installation de cet appareil.

These appliances comply with National Safety Standards and are tested and listed by PFS (Report No. F14-172) to ANSI Z21.50 (in Canada, CSA-2.22), and CAN/CGA-2.17-M91 in both USA and Canada, as vented gas fireplaces.

These appliances may be used in bedrooms (USA only) when the room is an "unconfined space" as defined by the National Fuel Gas Code. Use in bedrooms may not be allowed by your local building codes. You should obtain prior approval from the Authority having jurisdiction prior to installation.

Misc. Codes / Standards -

The Installation must conform to local codes or, in the absence of local codes, with the *National Fuel Gas Code, ANSI Z223.1/NFPA 54 - latest edition* (In Canada, the current CAN/CGA-B149.1 installation code).

The appliance, when installed, must be electrically grounded and wired in accordance with local codes or, in the absence of local codes, with the *National Electrical Code, ANSI/NFPA 70 - latest edition*, or the *Canadian Electrical Code, CSA C22.1 - latest edition*.

Provide adequate clearances around air openings and adequate accessibility clearance for service and proper operation. Never obstruct the front or back openings of the appliance.

These appliances are designed to operate on natural gas only. The use of other fuels or combination of fuels will degrade the performance of this system and may be dangerous.

These fireplaces are designed as decorative appliances and are not intended for use as area heaters. They must Not be equipped with wall thermostats or remote controls with thermostat functions.

These appliances must not be connected to a chimney or flue serving a separate solid fuel burning appliance.

The appliance area be kept clear and free from combustible materials, gasoline and other flammable vapors and liquids.

Millivolt Models - The millivolt appliances are manually controlled and feature a spark igniter (piezo) that allows the appliance's pilot gas to be lit without the use of matches or batteries. This system provides continued service in the event of a power outage. A manually-modulated gas valve is standard. Flame appearance and heat output can be controlled at the gas valve. The BTU Input for these appliances is shown in **Table 1**.

Input (BTU) Gas Valves (all models)		
All Models	Fuel Type	Input Rate (BTU / HR)
Millivolt	Natural	37,500 high - 30,000 low
Millivolt	Propane	34,000 high - 27,000 low

Table 1

Gas Pressure - All Models

Tables 2 and 3 show the appliances' inlet and manifold gas pressure requirements:

Inlet Gas Supply Pressure		
Fuel #	Minimum	Maximum
Natural Gas	4.5" WC (1.12 kPa)	10.5" WC (2.62 kPa)
Propane*	11.0" WC (2.74 kPa)	13.0" WC (3.24 kPa)

Table 2 *if field converted

Manifold Gas Supply Pressure		
Fuel #	Low	High
Natural Gas	2.2" WC (0.55 kPa)	3.5" WC (0.87 kPa)
Propane*	6.3" WC (1.57 kPa)	10.0" WC (2.49 kPa)

Table 3 *if field converted

Test gauge connections are provided on the front of the millivolt gas control valve (identified IN for the inlet and OUT for the manifold side). The control valves have a 3/8" (10mm) NPT thread inlet and outlet side of the valve (refer to **Figure 1**).

Propane tanks are at pressures that will cause damage to valve components. Verify that the tanks have step down regulators to reduce the pressure to safe levels.

The appliance and its appliance main gas valve must be disconnected from the gas supply piping system during any pressure testing of that system at test pressures in **excess of** 1/2 psi (3.5 kPa).

The appliance must be isolated from the gas supply piping system by closing its equipment shutoff valve during any pressure testing of the gas supply piping system at test pressures **equal to or less than** 1/2 psi (3.5 kPa).

Orifice Sizes - Sea Level to High Altitude (All Models)

These appliances are tested and approved for installation at elevations of 0-4500 feet (0-1372 meters) above sea level using the standard burner orifice sizes (marked with an "*" in **Table 4**). For elevations above 4500 feet, contact your gas supplier or qualified service technician.

Deration - At higher elevations, the amount of BTU fuel value delivered must be reduced by either:

- Using gas that has been derated by the gas company.
- By changing the burner orifice to a smaller size as regulated by the local authorities having jurisdiction and by the (USA) National Fuel Gas Code NFPA 54/ANSI Z223.1 - latest edition or, in Canada, the CAN/CGA-B149.1 codes - latest edition.

Install the appliance according to the regulations of the local authorities having jurisdiction and, in the USA, the National Fuel Gas Code NFPA 54 / ANSI Z223.1 - latest edition or, in Canada, the CAN/CGA-B149.1 - latest edition.

Flame breadth, height and width will diminish 4% for every 1,000 feet of altitude.

In Canada - CAN/CGA-2.17-M91 (R2009) (high altitude): THE CONVERSION SHALL BE CARRIED OUT BY A MANUFACTURER'S AUTHORIZED REPRESENTATIVE, IN ACCORDANCE WITH THE REQUIREMENTS OF THE MANUFACTURER, PROVINCIAL OR TERRITORIAL AUTHORITIES HAVING JURISDICTION AND IN ACCORDANCE WITH THE REQUIREMENTS OF THE CAN/CGA-B149.1 OR CAN/CGA-B149.2 INSTALLATION CODES.

Burner Orifice Sizes (all models)		
Elevation Feet (meters)	Natural Gas drill size (inches)	Propane Gas** drill size (inches)
0-4500 (0-1372)	#32 (0.116") * 37L82 •	1.65mm (.065")** 74L88 •

Table 4

* Standard size installed at factory
** If field converted.
• Part /Cat. Number

Gas Valve Diagrams

See **Figure 1** for Millivolt models.

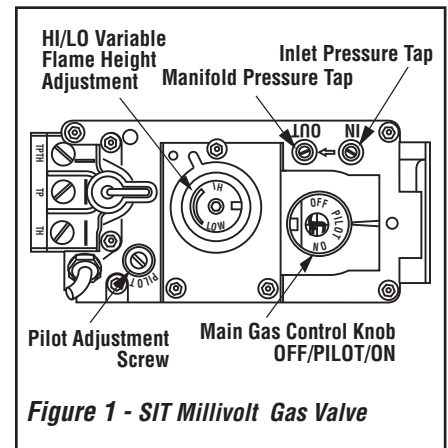

Figure 1 - SIT Millivolt Gas Valve

REQUIREMENTS FOR THE COMMONWEALTH OF MASSACHUSETTS

These appliances are approved for installation in the US state of Massachusetts if the following additional requirements are met:

- Install this appliance in accordance with Massachusetts Rules and Regulations 248 C.M.R. Sections 4.00 through 8.00.
- Installation and repair must be done by a plumber or gas fitter licensed in the Commonwealth of Massachusetts.
- The flexible gas line connector used shall not exceed 36 inches (92 centimeters) in length.
- The individual manual shut-off must be a T-handle type valve.

COLD CLIMATE INSULATION

For cold climate installations, seal all cracks around your appliance with noncombustible material and wherever cold air could enter the room. It is especially important to insulate outside chase cavity between studs and under floor on which appliance rests, if floor is above ground level. Gas line holes and other openings should be caulked or stuffed with unfaced fiberglass insulation.

If the fireplace is being installed on a cement slab in cold climates, a sheet of plywood or other raised platform can be placed underneath to prevent cold transfer to the fireplace and into the room. It also helps to sheetrock inside surfaces and tape for maximum air tightness and caulk firestops.

MANUFACTURED HOUSING

B-Vent Fireplaces are not approved for use in OEM or aftermarket manufactured housing built to HUD standards.

LOCATION

In selecting the location, the aesthetic and functional use of the appliance are primary concerns. However, vent system routing to the exterior and access to the fuel supply are also important.

Due to high temperatures, the appliance should be located out of traffic and away from furniture and draperies (Figure 2).

En raison des températures élevées, l'appareil devrait être installé dans un endroit où il y a peu de circulation et loin du mobilier et des tentures (Figure 2).

The location should also be free of electrical, plumbing or other heating/air conditioning ducting.

Be aware that this is a heat producing appliance. Objects placed above the unit are exposed to elevated temperatures.

Do not insulate the space between the appliance and the area above it.

The appliance must be mounted on a fully supported base extending the full width and depth of the unit. The appliance may be located on or near conventional construction materials. However, if installed on combustible materials, such as carpeting, vinyl tile or other combustible material other than wood flooring, the appliance shall be installed on a metal or wood panel extending the full width and depth of the appliance.

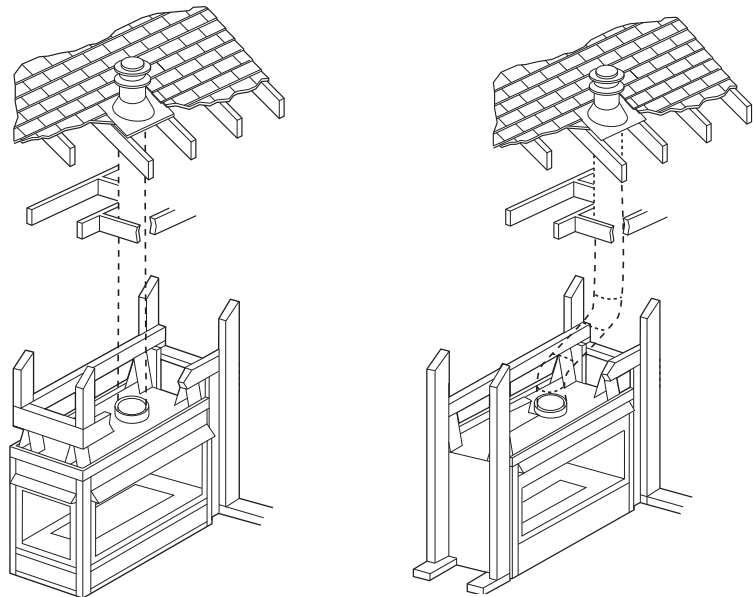

Vertical Venting

Offset Venting

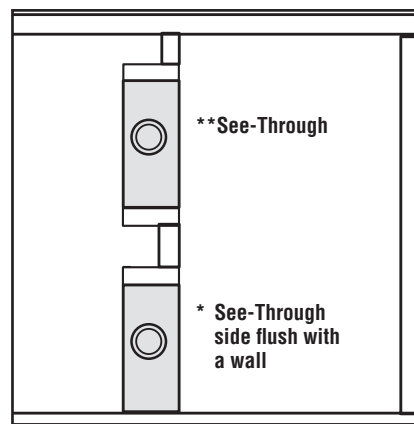

**** When the see-through fireplace is installed in the middle of a room, do not extend side walls beyond either viewing side of the fireplace.**

*** When the see-through fireplace is installed with one side flush with a wall, the opposite wall must not extend beyond either viewing side of the fireplace.**

Figure 2 - Typical Locations

VENT TERMINATION CLEARANCES

These instructions should be used as a guideline and do not supersede local codes in any way. Install venting according to local codes, these instructions, the current National Fuel Gas Code (ANSI-Z223.1) in the USA or the current standards of CAN/CGA-B149.1 in Canada.

Vertical Vent Termination Clearances

Gas Vent Rule - Gas vent caps are not permitted within 8 ft. (2.4 m) of a vertical wall or similar obstruction. Gas vent caps that are located 8 ft. or more from a portion of a building which extends at an angle greater than 45° upward from the horizontal may terminate in accordance with **Figure 4**, provided that in no case shall any discharge opening on the cap be less than 2 ft. (.6 m) horizontally from the roof surface (National Fuel Gas Code ANSI Z223.1 (NFPA 54) (CAN/CGA B149.1).

Multiple Terminations

These appliances may vent adjacent to and at the same level with any other gas appliances (including direct-vent appliances) provided that there is at least 2 ft. (0.6m) between the proximal edges of the vent caps. These appliances may be vented adjacent to a chimney vent servicing a solid fuel fireplace provided the B-vent cap is at least 2 ft. (0.6m) away from the nearest point of the chimney opening.

Vertical Vent Termination Clearances

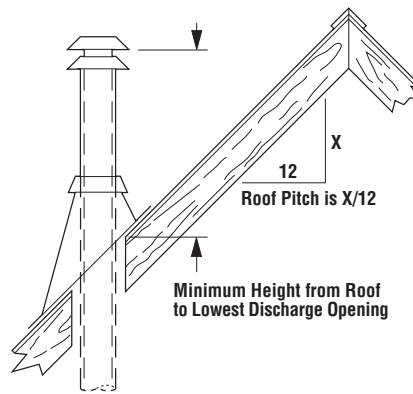

The vent / air intake termination clearances above the high side of an angled roof is as shown in the following chart:

Termination Heights For Vents Above Flat Or Sloped Roofs Ref. NFPA 54 / ANSI Z223.1		
Roof Pitch	* Feet	* Meters
Flat to 6/12	1.0	0.3
6/12 to 7/12	1.25	0.38
7/12 to 8/12	1.5	0.46
8/12 to 9/12	2.0	0.61
9/12 to 10/12	2.5	0.76
10/12 to 11/12	3.25	0.99
11/12 to 12/12	4.0	1.22
12/12 to 14/12	5.0	1.52
14/12 to 16/12	6.0	1.83
16/12 to 18/12	7.0	2.13
18/12 to 20/12	7.5	2.29
20/12 to 21/12	8.0	2.44

Figure 4

Multiple Terminations

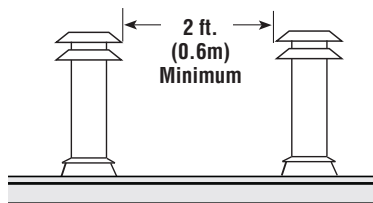

Figure 3

MINIMUM CLEARANCES TO COMBUSTIBLES

Appliance And Vent Clearances

The appliance is approved with zero clearance to combustible materials on all sides (as detailed in **Table 5**), with the following exception: **When the unit is installed with one side flush with a wall, the wall on the other side of the unit must not extend beyond the front edge of the unit** (see **Figure 2**).

MINIMUM CLEARANCES* Inches (millimeters)	
Back and Sides	1/2" (13) 0 (0) from Spacers Or Dimples **
Top Spacers	0 (0)
Floor	0 (0)
From Bottom of Unit To Ceiling	64 (1626)
Vent	3 (77) Top* / 1 (26) Sides & Bottom
SERVICE CLEARANCES Feet (meters)	
Front, Back, Sides	3 feet (0.9 meters)

Table 5

*NOTE: 3" (77 mm) above any inclined vent component.

**NOTE: See Page 11, Step 1 and Figure 8 for clearance requirements to the nailing flange located at each side of the unit and any screw heads adjacent to it.

Hearth Extension - A hearth extension is not required with this appliance. If a hearth extension is used, do not block the lower control compartment door. Any hearth extension used is for appearance only and does not have to conform to standard hearth extension installation requirements.

Wall Finishes / Surrounds / Mantels

NOTE: Combustible wall finish materials and/or surround materials must not be allowed to encroach the area defined by the appliance front face (black sheet metal). **Never allow combustible materials to be positioned in front of or overlapping the appliance face** (see **Figure 6 on Page 9** and **Figure 27 on Page 22**).

Non-combustible materials, such as surrounds and other appliance trim, may be installed on the appliance face with these exceptions: they must not cover any portion of the removable glass panel or control compartment.

Vertical installation clearances to combustible mantels vary according to the depth of the mantel. See **Figure 5**. Mantels constructed of non-combustible materials may be installed at any height above the appliance opening; however, do not allow anything to hang below the fireplace hood.

Minimum clearance requirements include any projections such as shelves, window sills, mantels, etc. above the appliance.

NOTE: To avoid heat-related finish damage, we recommend the use of high temperature paint (rated 175° F or higher) on the underside of the mantel.

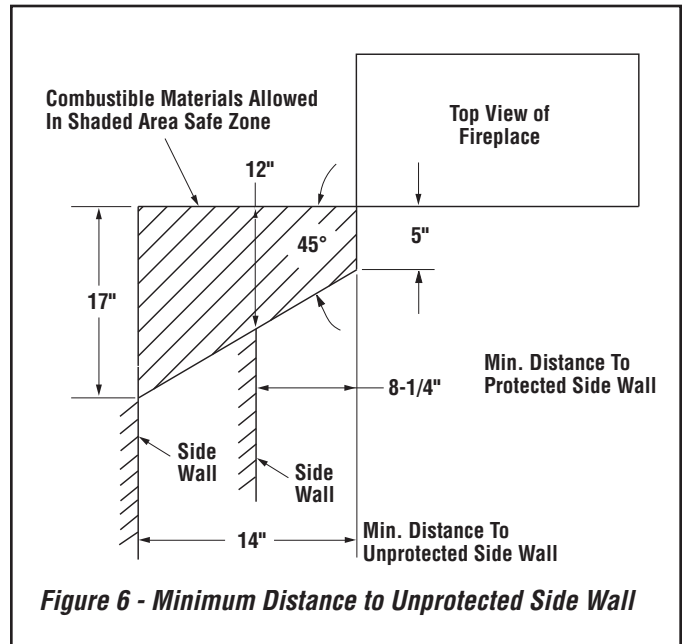
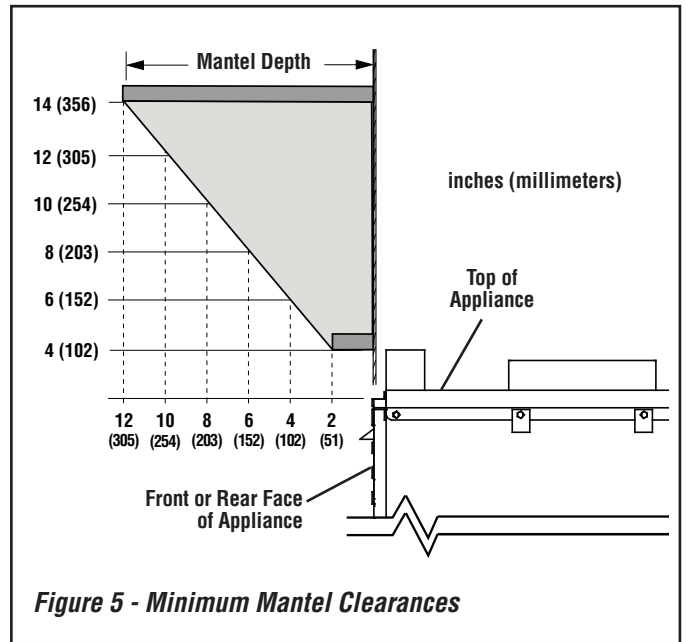

PRE-INSTALLATION STEPS

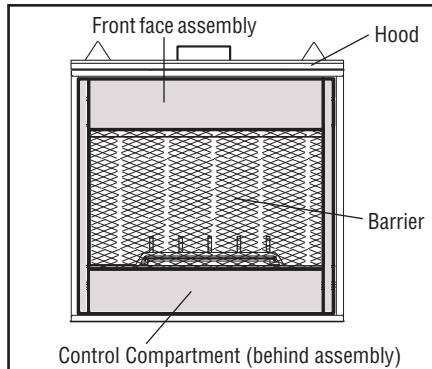

Figure 7 - Unit Parts Identification

The appliance is shipped with all gas controls and components installed and pre-wired.

1. Remove the shipping carton.
2. Remove hood by pulling away from unit (see **Figure 7**).
3. Remove front face assembly and barrier by lifting approximately 1/2" and pulling away from unit (see **Figure 7**).
4. Remove the modesty panel by pulling the bottom right corner of the modesty panel out slightly to disengage the snap-fit feature; lift the modesty panel by the tab on the panel's right end, pull the right end of the panel away from the cabinet and then pull the panel diagonally out of the left side cabinet panel slots. Remove the modesty panel carefully, so that none of the wires become loose or disconnected.
5. Open the latch (located under the firebox floor) securing the glass enclosure panel. Remove the panel by tilting it outward at the bottom and lifting it up. Set the door aside protecting it from inadvertent damage. See **Figure 24 on Page 21**.
6. Remove log set box from firebox. Next, remove embers, vermiculite and volcanic stone from control compartment. Handle logs carefully to prevent breakage.

TYPICAL INSTALLATION SEQUENCE

The typical sequence of installation is outlined below. However, each installation is unique and may result in variations to the steps described.

See the page numbers references in the following steps for detailed procedures.

Step 1. (Page 11) Construct the appliance framing. Position the appliance within the framing and secure with nailing brackets and floor anchor tabs.

Step 2. (Page 13) Route gas supply line to appliance location.

Step 3. (Page 13) Install the vent system and exterior termination.

Step 4. (Page 14) Field Wiring

- a. Millivolt Appliances - The operating control switch is factory installed.

Step 5. (Page 15) Make connection to gas supply.

Step 6. (Page 16) Install and verify outside air kit operation.

Step 7. (Page 17) Checkout appliance operation.

Step 8. (Page 18) Install the log set, vermiculite, volcanic stone and glowing embers.

Step 9. (Page 21) Removing and Installing glass enclosure panels.

Step 10. (Page 21) Adjust burner primary air shutter to achieve proper flame appearance.

Step 11. (Page 22) Install front face assembly with barrier and hoods.

Step 12. (Page 23) Conduct limit switch spillage test.

Step 13. (Page 24) Attach safety in operation warnings.

NOTE: Front Face Assembly with barrier installed must be reinstalled prior to operation.

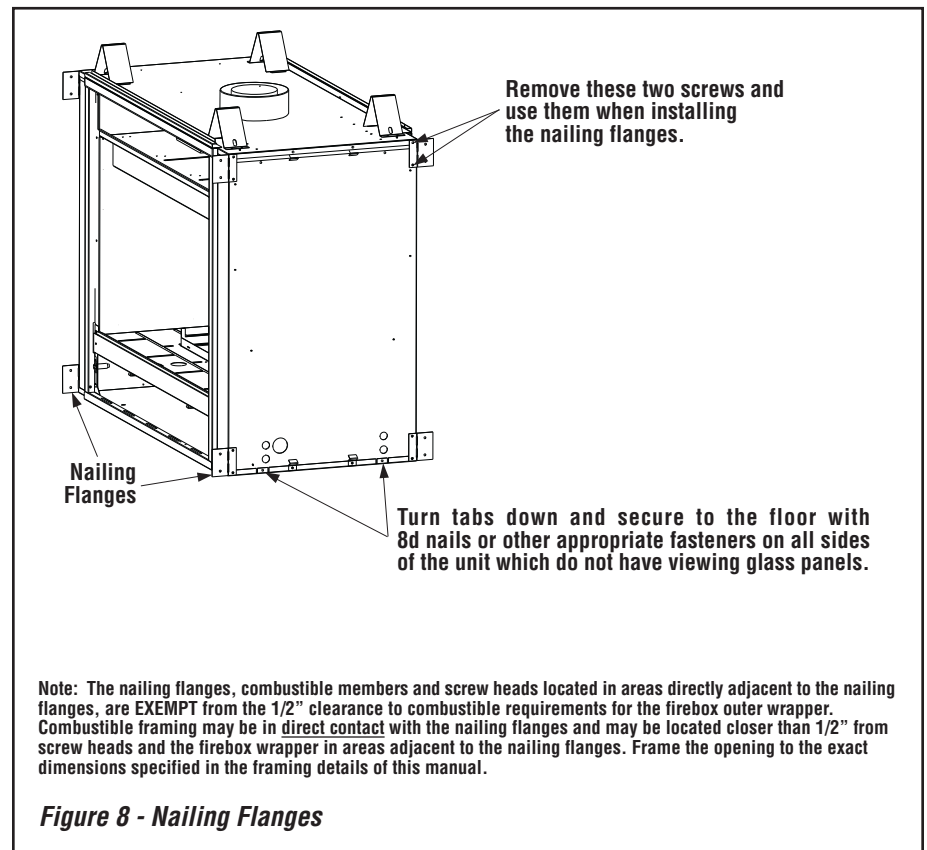

Step 1. FRAMING

Frame this appliance as illustrated in **Figure 9**. All framing details must allow for a minimum clearance to combustible framing members as shown in **Table 5 on Page 9**. If the appliance is to be elevated above floor level, a solid continuous platform must be constructed. Headers may be in direct contact with the appliance top spacers but must not be supported by them or notched

to fit around them. All construction above the appliance must be self supporting, **DO NOT** use the appliance for structural support.

Side Nailing Flanges

The fireplace should be secured to the framing at the side(s) and/or rear of the unit using the factory-provided nailing flanges. Install the 8 nailing flanges as shown in **Figure 8** using the existing screws.

Position the fireplace within the framing. When required, the flanges may be bent 90 degrees by hand or with the assistance of a hammer. Use wood screws to secure the nailing flanges to the framing. **See Table 5 on Page 9** for clearances of framing members to cabinet parts in the nailing flange area. The nailing flange itself is exempt from these clearances.

Floor Nailing Tabs

Secure the fireplace to the floor as shown in **Figure 8**.

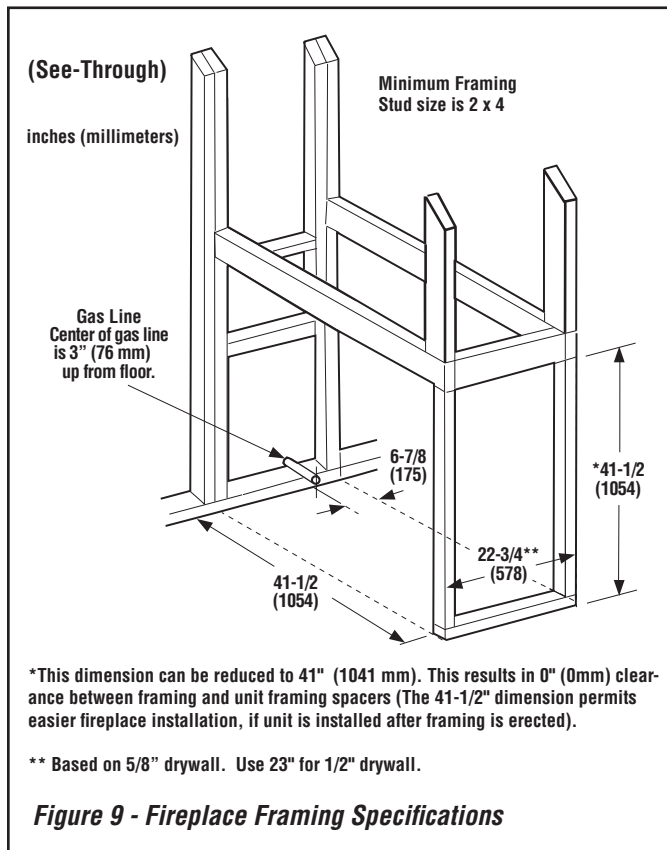

FIREPLACE SPECIFICATIONS

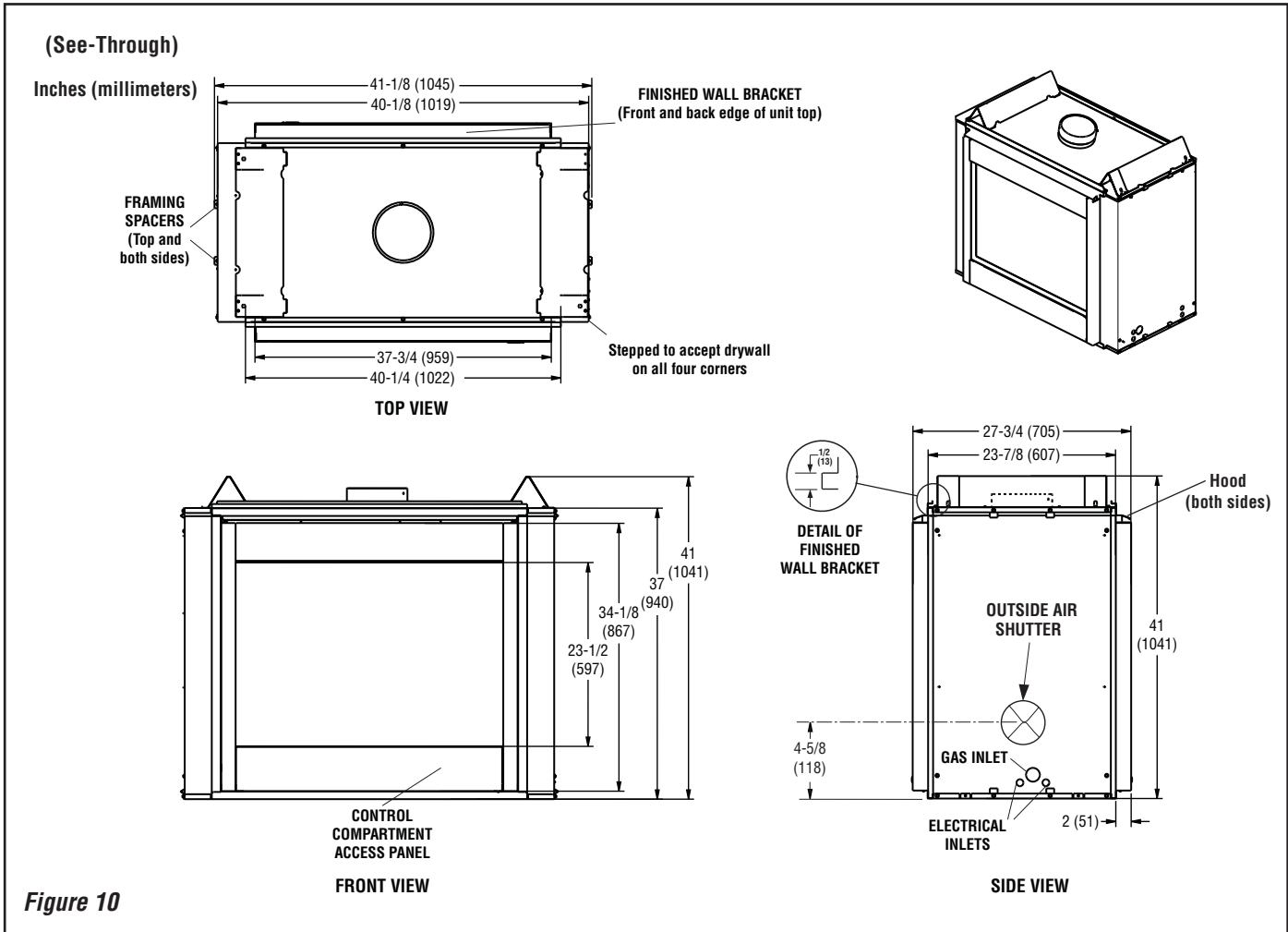

Step 2. ROUTING GAS LINE

Route a 1/2" (13 mm) gas line to the left side of the appliance as shown in **Figure 11**. Gas lines must be routed, constructed and made of materials that are in strict accordance with local codes and regulations. All appliances are factory-equipped with a flexible gas line connector and 1/2" shutoff valve. (See **Step 5 on Page 14**).

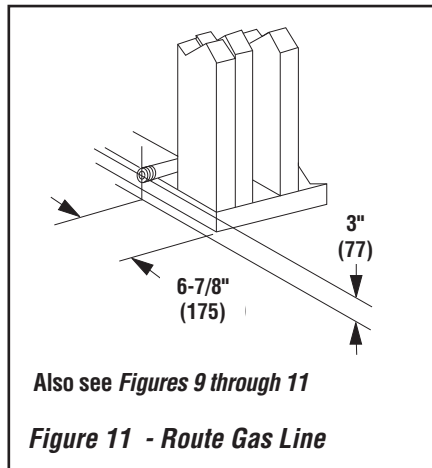

Proper Sizing of Gas Line

Properly size and route the gas supply line from the supply regulator to the area where the appliance is to be installed per requirements outlined in the National Fuel Gas Code, NFPA 54 - latest edition (USA) or CAN/CGA-B149.1 - latest edition (Canada).

Never use galvanized or plastic pipe. Refer to **Table 6** for proper sizing of the gas supply line, if black iron pipe is being used. Gas lines must be routed, constructed and made of materials that are in strict accordance with local codes and regulations. We recommend that a qualified individual such as a plumber or gas fitter be hired to correctly size and route the gas supply line to the appliance.

Installing a gas supply line from the fuel supply to the appliance involves numerous considerations of materials, protection, sizing, locations, controls, pressure, sediment, and more. Certainly no one unfamiliar and unqualified should attempt sizing or installing gas piping.

Schedule 40 Black Iron Pipe Inside Diameter (Inches)		
Schedule 40 Pipe Length (feet)	Natural Gas	Propane Gas
0-10	1/2	3/8
10-40	1/2	1/2
40-100	1/2	1/2
100-150	3/4	1/2
150-200	3/4	1/2

Table 6

NOTES:

- All appliances are factory-equipped with a flexible gas line connector and 1/2" shutoff valve.
- See **Massachusetts Requirements on Page 6** for additional requirements for installations in the state of Massachusetts in the USA.
- The gas supply line should Not be connected to the appliance until **Step 5 (Page 15)**.
- A pipe joint compound rated for gas should be used on the threaded joints. **Ensure propane resistant compounds are used in propane applications.** Be very careful that the pipe compound does not get inside the pipe.
- It is recommended to install a sediment trap in the supply line as close as possible to the appliance. Appliances using Propane should have a sediment trap at the base of the tank.
- Check with local building official for local code requirements (i.e. are below grade penetrations of the gas line allowed?, etc).

IMPORTANT: If propane is used, be aware that if tank size is too small (i.e. under 100-lbs, if this is the only gas appliance in the dwelling. Ref. NPFA 58), there may be loss of pressure, resulting in insufficient fuel delivery (which can result in sooting, severe delayed ignition or other malfunctions). Any damage resulting from an improper installation, such as this, is not covered under the limited warranty.

Step 3. INSTALL THE VENT SYSTEM

General Information

These instructions should be used as a guideline and do not supersede local codes in any way. Install venting according to local codes, these instructions, the current National Fuel Gas Code (ANSI-Z223.1) in the USA or the current standards of CAN/CGA-B149.1 in Canada.

Ensure clearances are in accordance with local installation codes and the requirements of the gas supplier.

Dégagement conforme aux codes d'installation locaux et aux exigences du fournisseur de gaz.

These fireplaces must be vented directly to the outside.

The vent system may not service multiple appliances, and must never be connected to a flue serving a solid fuel burning appliance. The vent pipe is tested to be run inside an enclosed wall (such as a chase). There is no requirement for inspection openings in the enclosing wall at any of the joints in the vent pipe.

In the United States, vent installation must conform with local building codes. In the absence of local codes, vents must be installed in accordance with the current edition of the National Fuel Gas Code (ANSI-Z223.1).

In Canada, vent installation must conform with local building codes. In the absence of local codes, vents must be installed in accordance with the current edition of the National Standard of Canada CAN/CGA-B149.1 or B149.2 Installation Code.

This gas fireplace must be vertically vented using listed 6" type-B, double-walled vent pipe and a listed vent termination.

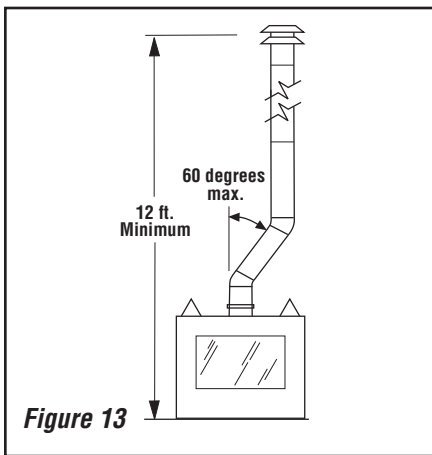
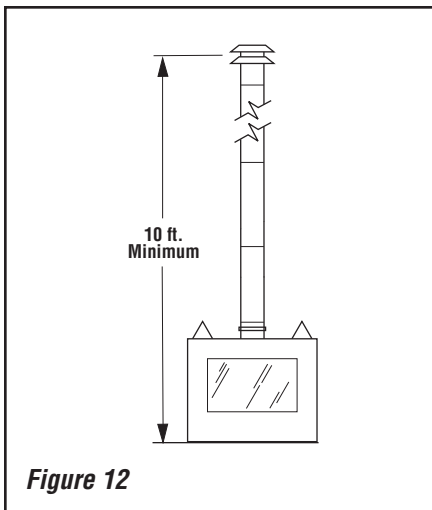

Slip the first 6" (152 mm) section of B-Vent over the fireplace flue outlet and secure with four sheet-metal screws (# 8 or larger), and install the remainder of the B-Vent to the outside. Minimum overall height of the vent system and appliance must be 10' (2.54 m) vertical - no offset (see **Figure 12**); or 12' (3.7 m) when an offset up to 60 degrees from the vertical is used - this offset may start at the fireplace flue collar (see **Figure 13**). **The maximum overall height of the vent system and appliance should not exceed 40 feet.**

Install the B-vent system in accordance with the vent manufacturer's instructions.

CAUTION: THIS APPLIANCE CANNOT BE VENTED HORIZONTALLY.

NOTE: Refer to the vent manufacturers installation instructions for variations of venting techniques. If common venting of several units is contemplated, it should be discussed with an architect and the local Building Department.

Do not place insulation materials within 1" of the gas vent system.

Step 4. FIELD WIRING

CAUTION: Label all wires prior to disconnection when servicing controls. Wiring errors can cause improper and dangerous operation.

ATTENTION: Au moment de l'entretien des commandes, étiquetez tous les fils avant de les débrancher. Des erreurs de câblage peuvent entraîner un fonctionnement inadéquat et dangereux.

Verify proper operation after servicing.

S'assurer que l'appareil fonctionne adéquatement une fois l'entretien terminé.

Refer to Section A for millivolt appliances. The gas valve is set in place and pre-wired at the factory on both models.

A. Millivolt Wiring (See Figure 14)

Install Optional Control Switch (OFF/ON wall switch or remote control receiver). Install snap bushing (on brown wall switch wire) into control switch knock-out in side panel (see **Figure 10**). Wire the optional control switch within the millivolt control circuit (as shown in **Figure 14**) using the 15 feet of brown 2-conductor wire supplied (route wires through the snap bushing to the optional control switch). Mount the optional control switch in a convenient location on a wall near the fireplace.

CAUTION
Do not connect optional control switch to 120 VAC power supply.

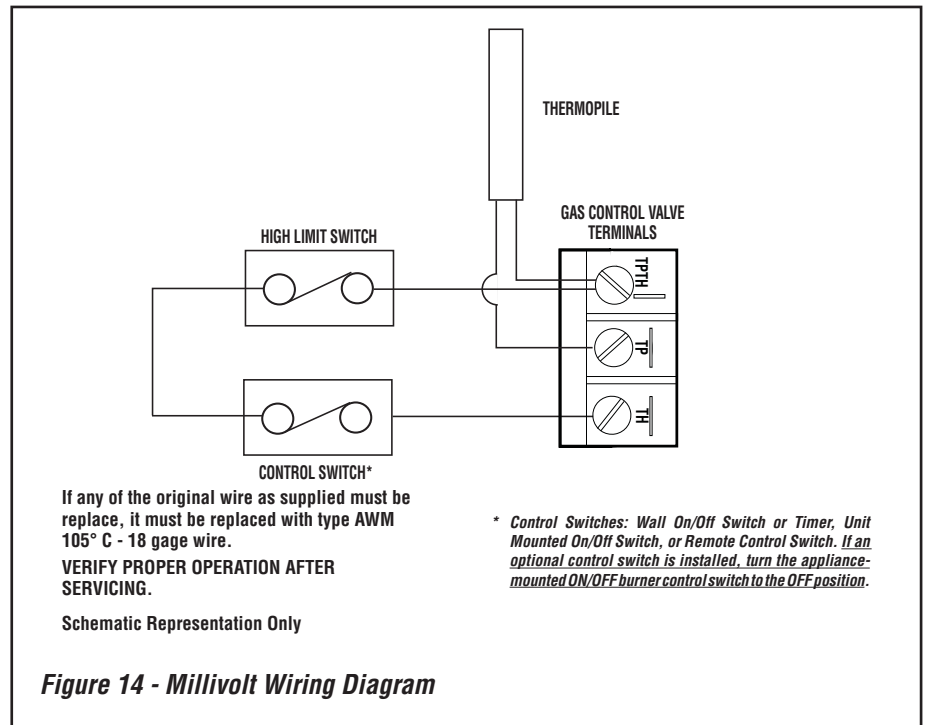

STEP 5. CONNECTING GAS LINE

Make gas line connections. All codes require a shut-off valve mounted in the supply line. **Figure 15** illustrates two methods for connecting the gas supply. The flex-line method is acceptable in the U.S., however, Canadian requirements vary depending on locality. Installation must be in compliance with local codes.

A sediment trap is recommended in the gas piping within the home to prevent moisture and debris in the line from damaging the valve.

These appliances are equipped with a gas flex line for use (where permitted) in connecting the unit to the gas line. A gas flex line is provided to aid in attaching the appliance to the gas supply. The gas flex line can only be used where local codes permit.

The flex line is rated for both natural and propane gas. A manual shut off valve is also provided with the flex line. The gas control valve is located in the lower control compartment.

To access the valve open the lower control compartment door (*see Figure 17*) by pushing in the right top corner of the door. (The door is hinged at the bottom). Remove the bottom compartment door by sliding the hinge pin, located at the door's left side, to the right until it disengages from the left corner post hole. Pull the door diagonally to the left, away from the fireplace.

The lower control compartment door on the side opposite the valve lifts on and off.

The millivolt control valve has a 3/8" (10 mm) NPT thread inlet port.

Secure all joints tightly using appropriate tools and sealing compounds (ensure propane resistant compounds are used in propane applications).

All codes require a shut-off valve mounted in the supply line. The orientation of the shut-off valve should face the front. **Figure 15** illustrates two methods for connecting the gas supply.

A sediment Trap is recommended to prevent moisture and debris in the gas line for damaging the valve.

TEST ALL CONNECTIONS FOR GAS LEAKS (FACTORY AND FIELD):



Turn on gas supply and test for gas leaks, using a gas leak test solution (also referred to as bubble leak solution).

NOTE: Using a soapy water solution is an effective leak test solution but it is not recommended, because the soap residue that is left on the pipes/fittings can result in corrosion over time.

- Light the appliance (refer to the lighting instructions label in the control compartment or in the Installation and Operation Instructions manual).
- Brush all joints and connections with the gas leak test solution to check for leaks. If bubbles are formed, or gas odor is detected, turn the gas control knob (off/pilot/on) to the "OFF" position. Either tighten or refasten the leaking connection, then retest as described above.
- When the gas lines are tested and leak free, be sure to rinse off the leak testing solution.

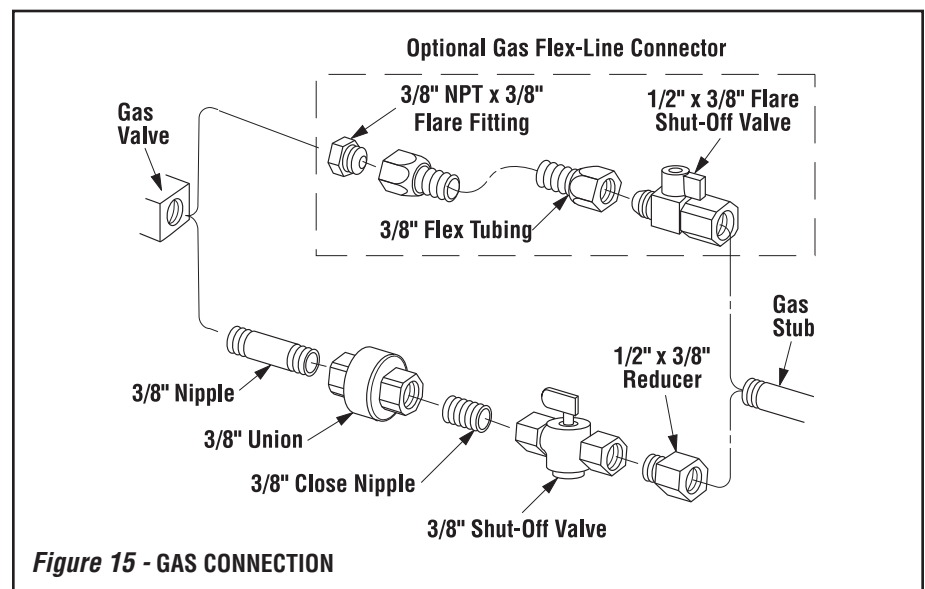

Step 6. OUTSIDE AIR KITS

Optional outside make-up air kits, Model FOAK-4 or FAOK-4LD, may be used with these appliances. Refer to the installation instructions packaged with the air kits for specific installation information. If used, the outside air kit must be installed before the fireplace is framed and enclosed in the finished wall.

Outside air drawn into the fireplace supplies air to the fire for combustion. Only one outside air duct is necessary, if installed. See the **Figure 11** for the location of the units outside air inlet.

If additional length of duct is necessary, purchase locally available U.L. Class 0 or Class 1 metallic ducting. The duct may extend up to 50' (15.24 m) in any direction.

NOTE: When installing the air duct vertically, **DO NOT** terminate the duct closer than 3' below the chimney top.

Outside combustion air ducting may be run upwards or vertically through framing and ceiling joists, with the hood installed through an outside wall and 3' (1 m) below the termination. Ducting may also be run downward through floor Joists and under the home to a ventilated crawlspace not considered part of the living area of the home.

NOTE: Do not terminate outside air kit in attic space under any circumstances.

CAUTION: NEVER LOCATE INLET WHERE IT CAN BE BLOCKED BY SHRUBS, SNOW DRIFTS, ETC. NEVER LOCATE INLET IN GARAGE OR ANY AREA WHERE THERE IS ANOTHER FUEL BURNING APPLIANCE OR PRODUCTS EMITTING COMBUSTIBLE GASES SUCH AS PAINT, GASOLINE, ETC. IN COLD CLIMATES, IT IS RECOMMENDED THE COMBUSTION AIR DUCT BE INSULATED.

After completing the installation of the optional outside air vent system, the outside air control lever must be put in service and tested to ensure proper operation before completing any enclosure around the firebox. Failure to do so may result in extensive and costly rework.

Before the operation of the vent system can be tested, the lever securing screw must be removed. **See Figure 16.**

The hand operated outside air control lever is located on the right side of the fireplace opening. **See Figure 16.**

To open the outside air shutter, open the bottom control access panel, reach into the gap between the firebox bottom and the modesty panel, and pull the outside air control lever all the way out.

The outside air shutter should be fully open when the fireplace is in use and completely closed when the fireplace is not being used. Closing it when not in use will prevent outside cold air from entering the dwelling.

Operate the actuator through several cycles including the closed position. Ensuring proper operation and freedom of movement. Return the actuator arm to the closed position.

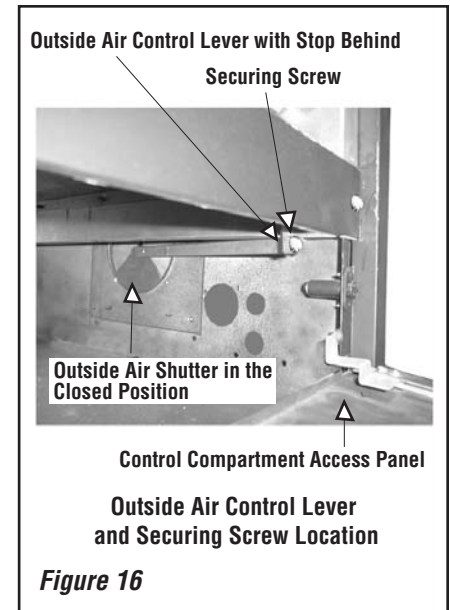

Step 7. VERIFYING APPLIANCE OPERATION

Turn on burner and observe the individual tongues of flame on the burner. Make sure all ports are open and producing flame evenly across the burner. If any ports are blocked, or partially blocked, clean out the ports.

With gas line installed run initial system checkout before closing up the front of the unit. Follow the pilot lighting instructions provided in the Installation and Operation Instructions manual. For piezo igniter location see **Figure 17** (millivolt appliances only).

NOTE: Lighting Instructions are also found on the literature tag tied to the gas piping next to the gas valve. To access the tag, open the lower control compartment door (**Figure 17**) by pushing in simultaneously the left and right top corners of the door. (The door is hinged at the bottom). Remove the bottom compartment door by sliding the hinge pin, located at the door's left side, to the right until it disengages from the left corner post hole. Remove the modesty panel. To remove the modesty panel, slide the panel forward until it contacts the cabinet bottom panel, then lift straight up and tilt forward. Remove the modesty panel carefully, so that none of the wires become loose or disconnected.

When first lighting the appliance, it will take a few minutes for the line to purge itself of air. Once purging is complete, the pilot and burner will light and operate as indicated in the instruction manual.

Subsequent lighting of the appliance will not require such purging. Inspect the pilot flame (remove logs, if necessary, handling carefully).

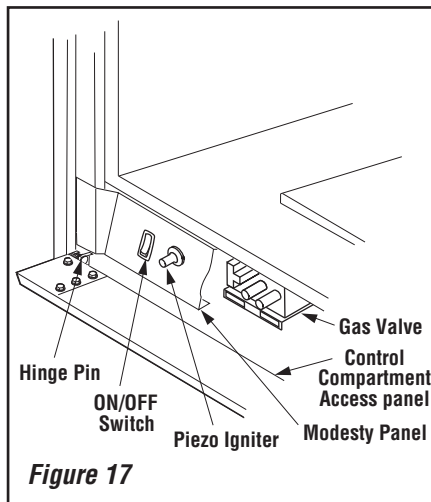

Millivolt Appliance Checkout

The pilot flame should be steady, not lifting or floating. Flame should be blue in color with traces of orange at the outer edge.

The top 3/8" (10 mm) at the pilot generator (thermopile) and the top 1/8" minimum (tip) of the quick drop out thermocouple should be engulfed in the pilot flame.

The flame should project 1" (25 mm) beyond the hood at all three ports (see **Figure 18**). Replace logs if removed for pilot inspection.

To light the burner; turn "ON" the remote wall switch and rotate the gas valve control knob counterclockwise to the "ON" position ("ON" will be at the top side of the valve).

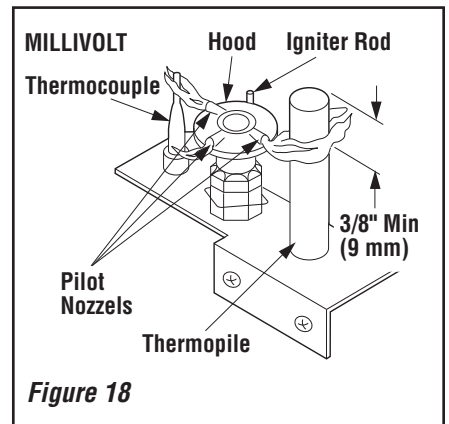

Step 8. INSTALL VERMICULITE, GLOWING EMBERS AND LOGS

NOTE: It is important to ensure proper log placement per the manual when installing these units. Verify pilot flame is not obstructed. See Verifying Appliance Operation on **Page 17**.

NOTE: Turn off all electricity to the appliance before you install vermiculite, embers and logs. DO NOT attempt to install the logs until the appliance installation has been completed, the gas line connected and tested for leaks and the initial burner operation has been checked out.

INSTALLATION STEPS:

READ WARNINGS ON THIS PAGE BEFORE PROCEEDING. FOLLOW THE LOG PLACEMENT INSTRUCTIONS EXACTLY

1. **Remove the front glass enclosure panel** (see *Glass Enclosure Panel Removal and Installation Instructions, Page 21*).
2. **Remove the following from firebox:** log set, bag of embers and bag of vermiculite. **Handle logs carefully to prevent breakage.**
3. **Ensure the Grate is properly installed** in the firebox with the 4 legs of the grate fitting into the 4 dimples on the firebox floor.
4. **Placement of Glowing Embers -**
 Separate the Embers (rockwool) into pieces about the size of a quarter (see **Figure 19**). Keep the pieces fluffed up, not matted. Distribute these pieces over the surface of the burner, as shown in **Figure 20**. Do not use more than is necessary. Ensure that the main burner ports remain uncovered by the ember material.
5. **Place Volcanic Stone -** Spread volcanic stone evenly over firebox floor.
6. **Install Vermiculite -** Place some vermiculite on the firebox floor around the grate (the entire bag of vermiculite will NOT be used). **DO NOT PLACE ANY VERMICULITE ON THE BURNER.**

NOTE: This appliance is provided with enough Glowing Embers for several applications, do not use all that is in a new bag at one time. For best glowing effect, replace the ember material annually. Replacement Glowing Embers are available (order Catalog Number 88L53).

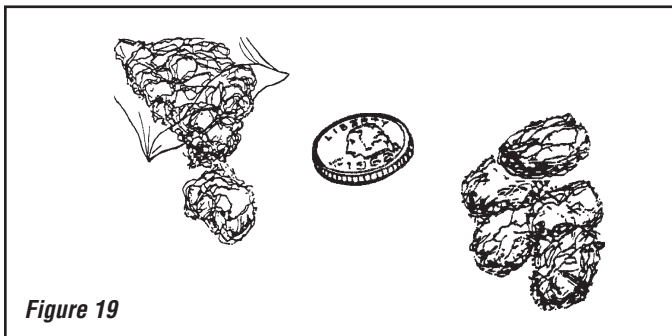

Figure 19

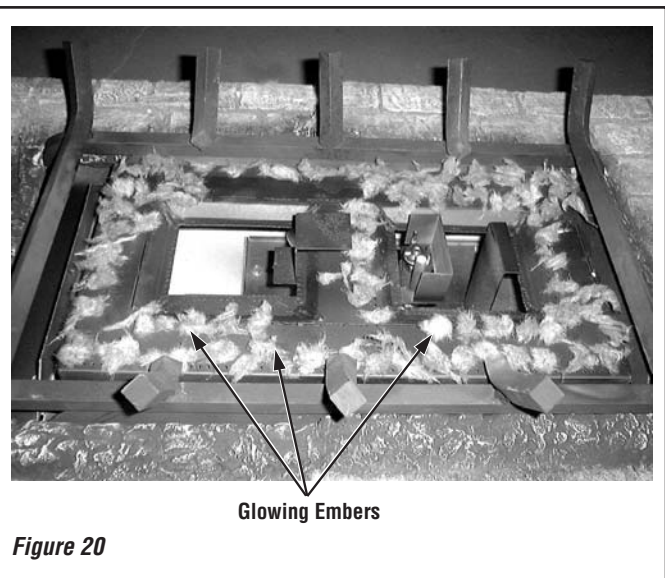

Figure 20

! WARNING

- **DO NOT attempt to install the logs until the appliance installation has been completed, the gas line connected and tested for leaks and the initial burner operation has been checked out.**
- **The size and position of the log set was engineered to give the appliance a safe, reliable and attractive flame pattern. Any attempt to use a different log set in the fireplace will void the warranty and will result in incomplete combustion, sooting, and poor flame quality.**
- **Logs get very hot and will remain hot up to one hour after gas supply is turned off. Handle only when logs are cool. Turn off all electricity to the appliance before you install grate, volcanic stone, vermiculite, embers and logs.**
- **This appliance is not designed to burn wood. Any attempt to do so could cause irreparable damage to the appliance and prove hazardous to your safety.**
- **If logs are not installed according to the log installation instructions, flame impingement and improper combustion could occur and result in soot and/or excessive production of carbon monoxide (CO), a colorless, odorless, toxic gas.**

REFERENCE Firebox Accessories / Parts		
Cat. No.	Model No.	Description
88L53	FGE	Bag of Glowing Embers
80L42	FDVS	Bag of Decorative Volcanic Stone
H6319	----	Bag of Vermiculite

MARIN40ST LOG PLACEMENT

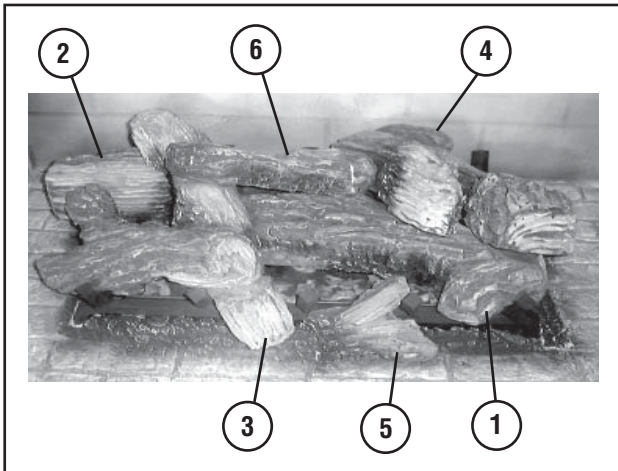

Log Number	Description
1	Log, Corner
2	Log, Rear/Left
3	Log, Front/Left
4	Log, Rear/Right
5	Log, Front/Center
6	Log, Center/Top

Catalog Number for the entire log set: 55M04

STEP 1

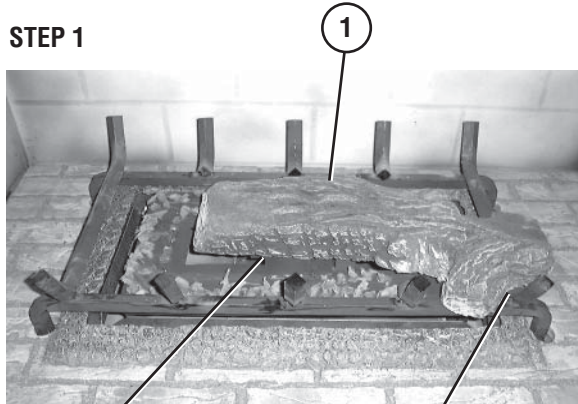

Position Groove At The Bottom Of Log (1) Over The Burner Log Support Bracket

Position The Groove At The Bottom Of Log (1) Over The Grate And Slide It Forward Against The Grate Here

STEP 2

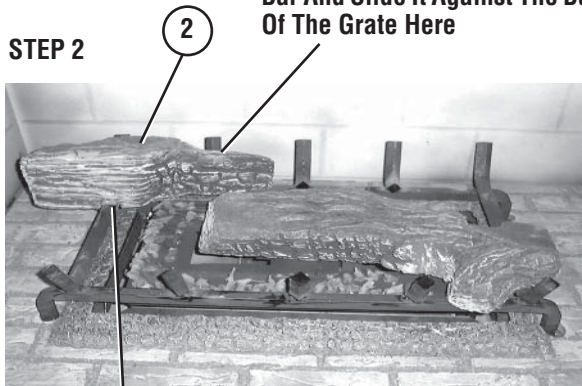

Position Groove At The Bottom Of Log (2) Over The Grate Here And Slide It Against The Back Of The Grate

Position Log (2) Over The Grate Bar And Slide It Against The Back Of The Grate Here

STEP 3

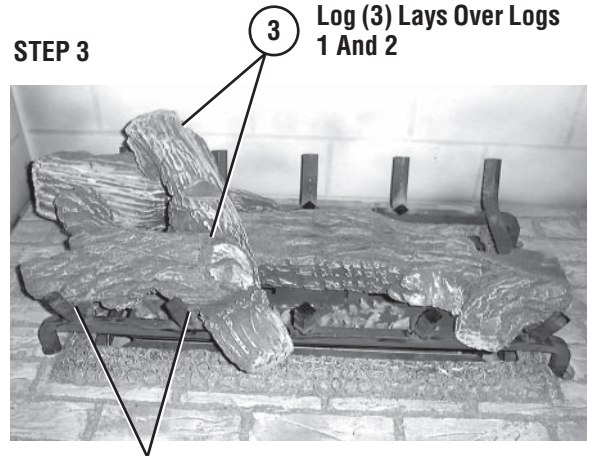

Place Bottom Hole Of Log (3) On Pin In Log (2). Position Grooves At The Bottom Of Log (3) Over The Grate.

Log (3) Lays Over Logs 1 And 2

STEP 4

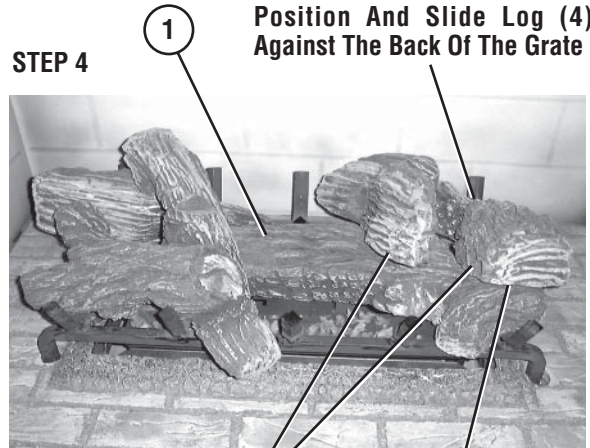

Place Log (4) Over The Flat Spot On Log (1) Here

Position And Slide Log (4) Against The Back Of The Grate

Figure 21

MARIN40ST LOG PLACEMENT (CONTINUED)

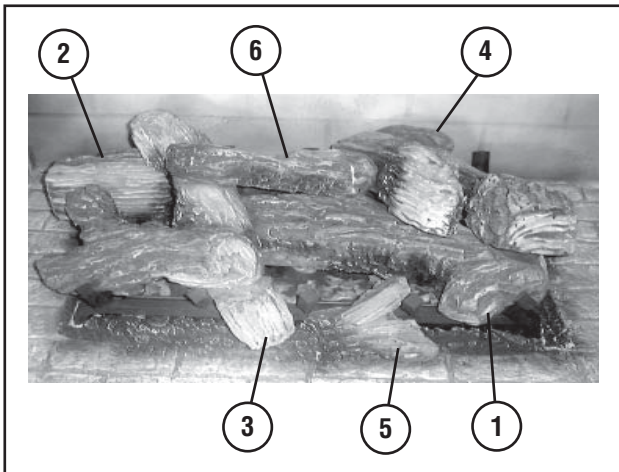

Log Number	Description
1	Log, Corner
2	Log, Rear/Left
3	Log, Front/Left
4	Log, Rear/Right
5	Log, Front/Center
6	Log, Center/Top

Catalog Number for the entire log set: 55M04

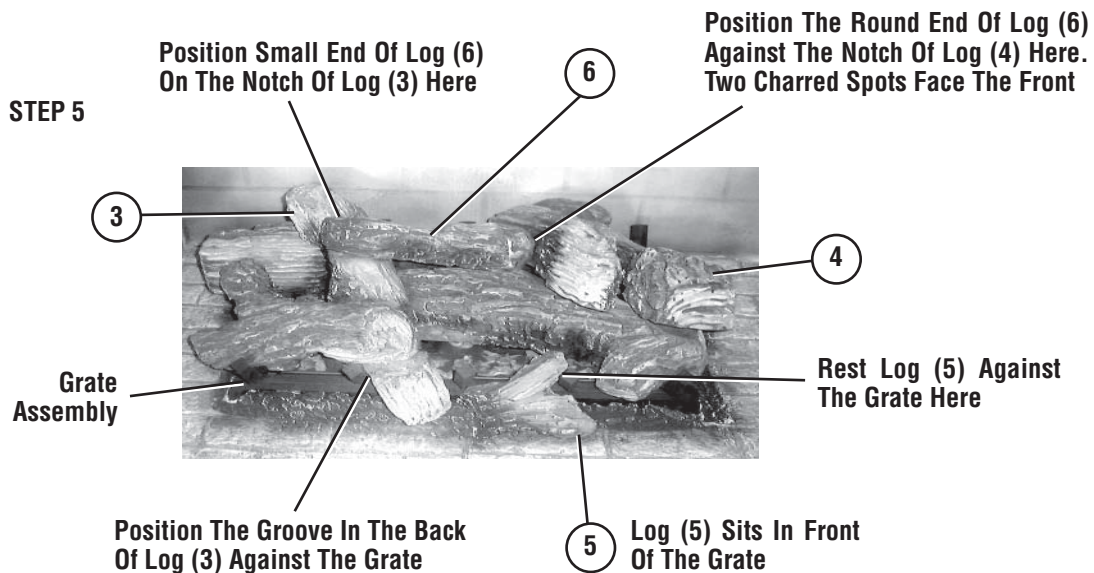
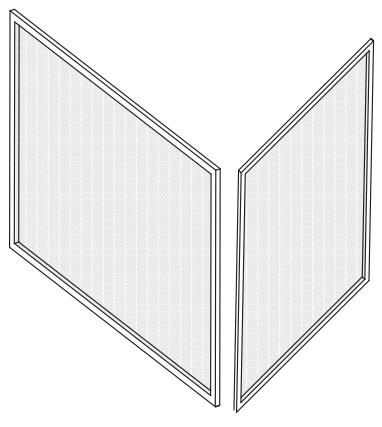

Figure 22

NOTICE: Marin40ST model fireplaces include barriers to reduce the risk of burns from hot viewing glass. The barriers in the fireplace are screens shown right.

J7420 (40" Models)

Figure 23



WARNING

Any safety screen, guard, or barrier removed for servicing an appliance must be replaced prior to operating the appliance.

NOTE:

- If the barrier becomes damaged, the barrier shall be replaced with the manufacturer's barrier for this appliance.
- For use with barrier(s) Part No(s). J7420.

Step 9. REMOVING AND INSTALLING THE GLASS DOOR

! WARNING

- Do not attempt to substitute the materials used on these doors, or replace cracked or broken glass.
- Handle this glass with extreme care! Glass is susceptible to damage - Do not scratch or handle roughly while reinstalling the glass door frame.
- The glass door(s) of this appliance must only be replaced as a complete unit as provided by the manufacturer. Do not attempt to replace broken, cracked or chipped glass separately.
- Do not attempt to touch the front enclosure glass with your hands while the fireplace is in use.
- DO NOT abuse glass door by striking or slamming shut.

! WARNING

The door should easily close without needing to be pressed down. If it has to be pressed down to close, the gasket in the top of the door should be dressed so it lays on the glass.

! WARNING

Do not operate appliance with the glass front removed, cracked or broken.

! AVERTISSEMENT

Ne pas utiliser l'appareil si le panneau frontal en verre n'est pas en place, est craqué ou brisé.

Only doors certified with the appliance shall be used.

Seules des portes certifiées pour cet appareil doivent être utilisées.

These are B-vent appliances. They are designed to operate only when the glass enclosure panels are installed. Generally the glass enclosure panels should not be removed except to gain access to the components within the firebox.

Removing Glass Enclosure Panel (see Figure 24)

To access the glass door securing latches, first remove the hood by pulling firmly straight away from the unit. Remove the front face assembly by lifting up top and bottom evenly approximately 1/2" and pulling straight out from the unit once the brackets are disengaged.

Locate the latch at the top of the control compartment and disengage them from the door frame bottom vee-flange, pulling down on its handle to open it.

Installing Glass Enclosure Panel (see Figure 24)

Retrieve the glass door. Visually inspect the gasket on the backside of the frame. Gasket surface must be clean, free of irregularities and seated firmly.

Position the door in front of the firebox opening with the bottom of the door held away from the fireplace (Figure 24). Hook the top flange of the door frame over the top of the firebox frame.

Let the bottom of the door frame swing gently in towards the fireplace ensuring that the gasket seats evenly as the door frame draws shut. Fasten the latch located underneath the firebox floor to the door's vee-flange. Close the latch securely.

NOTE: Front Face Assembly with barrier installed must be reinstalled prior to operation.

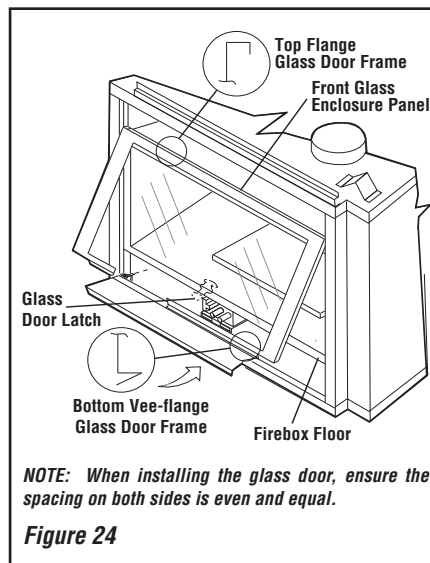

NOTE: When installing the glass door, ensure the spacing on both sides is even and equal.

Figure 24

Step 10. BURNER ADJUSTMENTS

Flame Appearance and sooting

Proper flame appearance is a flame which is blue at the base and becomes yellowish-orange in the body of the flame.

When the appliance is first lit, the entire flame may be blue and will gradually turn yellowish-orange during the first 15 minutes of operation. If the flame remains blue, or if the flame is orange with evidence of sooting (black tip), the air shutter opening may need to be adjusted.

If the air shutter opening is closed too far, sooting may develop. Sooting is indicated by black puffs developing at the tips of very long orange flames. Sooting results in black deposits forming on the logs, appliance inside surfaces and on exterior surfaces adjacent to the vent termination.

Sooting is caused by incomplete combustion in the flames and lack of combustion air entering the air shutter opening. To achieve a warm yellowish-orange flame with an orange body that does not soot, the shutter opening must be adjusted between these two extremes.

Air Shutter Adjustment Guidelines

- If there is smoke or soot present, first check the log set positioning to ensure that the flames are not impinging on any of the logs. If the log set is properly positioned and a sooting condition still exists, then the air shutter opening should be increased.
- The more offsets in the vent system, the larger the air shutter opening will need to be.
- An appliance operated with the air shutter opened too far, may have flames that appear blue and transparent. These weak, blue and transparent flames are termed anemic.
- Propane models may exhibit flames which candle or appear stringy. If this is present and persists, adjust the air shutter to a more closed position, then operate the appliance for a few more minutes to ensure that the flame normalizes and the flames do not appear sooty.

The following chart is provided to aid you in achieving the correct air shutter adjustment for your installation.

Air Shutter Adjustment Guidelines:		
Amount of Primary Air	Flame Color	Air Shutter Adjustment
If air shutter is closed too far →	Flame will be orange →	Air shutter gap should be increased
If air shutter is open too far →	Flame will be blue →	Air shutter gap should be decreased

Burner Adjustment Procedure

! WARNING

- Air shutter adjustment should only be performed by a qualified professional service technician.
- Ensure glass enclosure panels are in place and sealed during adjustment.

! CAUTION

- Soot will be produced if the air shutter is closed too much. Any damage due to sooting, resulting from improperly setting the air shutter, is not covered under the warranty.
- The air shutter door and nearby appliance surfaces are hot. Exercise caution to avoid injury while adjusting flame appearance.

1. Refer to **Figure 25** for proper flame appearance. To adjust the flame, rotate the adjustment rod toward the back or toward the front of the fireplace (rod located in the lower control area). Position the air shutter to the factory setting as shown in the table in **Figure 26**.
2. Light appliance (follow lighting procedure on lighting label in control compartment or see the Care and Operation Manual).
3. Allow the burner to operate for at least 15 minutes while observing the flame continuously to ensure that the proper flame appearance has been achieved. If the following conditions are present, adjust accordingly.
 - If flame appears weak or sooty, adjust the air shutter, incrementally, to a more open position until the proper flame appearance is achieved.
 - If flame remains blue, adjust the air shutter, incrementally, to a more closed position until the proper flame appearance is achieved.
4. Leave the control knob (off/pilot/on) in the ON position (millivolt appliances) and the burner OFF/ON switch OFF (and remote switches, if applicable).



Glowing Embers (rockwool)

Figure 25 - Burner Flame Appearance

5. When satisfied that the burner flame appearance is normal, re-install the lower control compartment door then proceed to finish the installation.

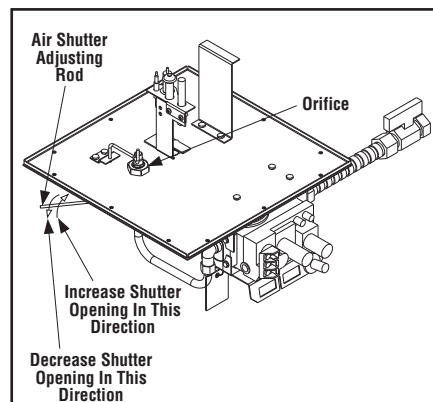

Note - Burners are omitted in this view for clarity.

MAIN BURNER FACTORY SHUTTER SETTING		
Model	Natural Gas inches (mm)	Propane Gas* inches (mm)
Marin40ST	1/16 (1.5)	7/16 (11)

* If field converted

Adjustment Rod Positions (when viewed from above)

Figure 26

Step 11. HOOD INSTALLATION

Refer to **Figure 27**. All of these appliances must have hoods installed prior to operating.

FINISHING REQUIREMENTS - Wall Details

Complete finished interior wall. To install the appliance facing flush with the finished wall, position framework to accommodate the thickness of the finished wall (**Figure 27**)

**See Page 7 for
Cold Climate Insulation and
Page 9 for Clearances**

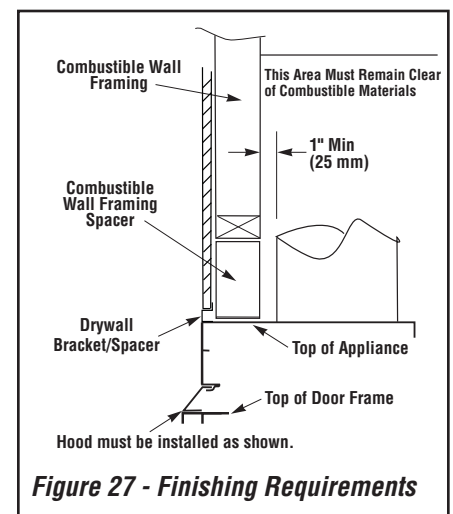

Figure 27 - Finishing Requirements

Step 12. Spillage Test and Safety Limit Switch Operation

Spillage Test

After appliance installation, perform this spillage test to verify that proper venting conditions exist:

- 1 - Place unit in its normally-operated condition, that is, with the glass enclosure panels in place.
- 2 - Close all doors and windows in the room. Turn on all exhaust fans in the house.
- 3 - Light the appliance.
- 4 - Wait 15 minutes.
- 5 - To check for venting action, start by holding a smoke producing device within an inch of one edge (side edge, not top or bottom edge) of one glass enclosure panel. The smoke should be drawn toward the edge of the glass enclosure panel. Continue the test by moving the smoke producing device along the entire length of both side-edges of the glass door. Repeat the test for all glass enclosure panels.
- 6 - **If the smoke is not drawn towards the edges of the glass door turn off the appliance and call a qualified service technician.**

Manually-Reset Safety Limit Switch

This appliance is equipped with a manually-reset blocked flue safety limit switch. Refer to **Figure 28** for its location. If, during appliance operation, the flame goes out (independently of the burner on/off wall switch), it may be due to the operation of this safety limit switch. **First allow the appliance to cool**, then reset the safety switch by pushing the red reset button on the back of the switch.

To access the blocked flue safety limit switch refer to **Figure 28**:

A - To access the blocked flue safety switch:

- 1 - Remove the hood by pulling directly out from the unit. Remove the front face assembly by lifting approximately 1/2" and pulling out from the unit.
- 2 - Reach between the cabinet side and the firebox side wall and locate the blocked flue safety switch.
- 3 - Push the red reset button on the switch.

The appliance should then relight and remain lit. If this does not occur, **turn off the appliance and call a qualified service technician.**

B - To access the blocked flue safety switch:

NOTE - This procedure should only be performed by a qualified service technician.
Important - Turn electrical power off before beginning this procedure.

- 1 - Open the lower bottom hinged panel on the control side of the fireplace. Remove the modesty panel and glass enclosure panel as described on **Pages 10 and 21**.
- 2 - Remove the side baffle securing screws (5) and then remove the baffle.
- 3 - Remove the safety switch bracket securing screws (2), and pull the switch/bracket assembly through the side panel slot.
- 4 - Push the red reset button on the switch.
- 5 - Reinstall the switch/bracket assembly.
- 6 - Reinstall the side baffle.
- 7 - Reinstall front glass door and front face assembly with barrier.
- 8 - Reinstall the hood.

The appliance should then relight and remain lit. If this does not occur, check unit for a blocked flue condition.

NOTE: Front Face Assembly with barrier installed must be reinstalled prior to operation.

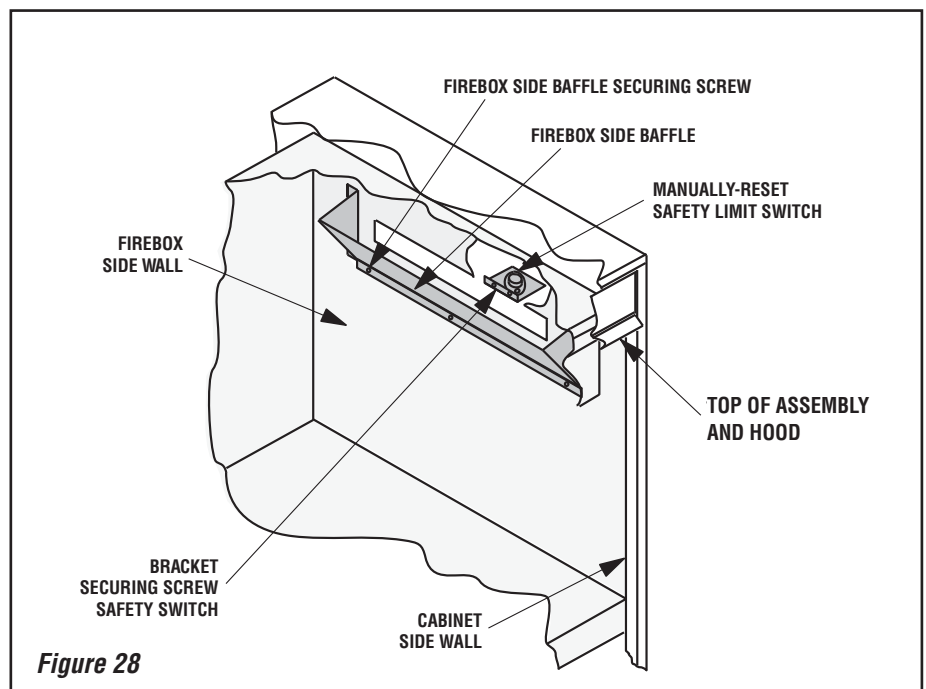

Figure 28

STEP 13. ATTACHING SAFETY IN OPERATION WARNINGS

It is the installers responsibility to ensure these warnings are properly affixed during installation. These warning labels are a critical step in informing consumers of safe operation of this appliance.

ATTACHING SAFETY IN OPERATION WARNINGS

It is required that the safety instruction labels furnished with the fireplace be affixed to the operation and control point of the fireplace. A safety instruction label must be affixed to the wall switch plate where the fireplace is turned on and off (See **Figure A**) and if used on the remote control handheld transmitter (**Figure B**). To properly complete the installation of this fireplace, locate the multi-lingual adhesive labels provided with the Care and Operation Instructions and proceed as follows:

1. Locate the wall switch that controls the fireplace (verify the switch operates the fireplace by turning it on and off). Clean the wall switch plate thoroughly to remove any dust and oils. Affix the label to the surface of the plate of the wall switch that controls the fireplace (**Figure A**). Choose the language primarily spoken in the home. If unknown, affix the English language label.
2. If a remote control is used to control the fireplace, locate the transmitter and clean it thoroughly to remove any dust and oils. Affix the label to the surface of handheld transmitter (**Figure B**). Choose the language primarily spoken in the home. If unknown, affix the English language label.
3. If you are unable to locate the labels, please call Innovative Hearth Products or your nearest Innovative Hearth Products dealer to receive additional safety instruction labels free of charge.

Cat. No. H8024 Replacement Label Kit

NOTE: English is red text on clear label. French and Spanish are white text on black label.

SAFETY LABEL DIAGRAMS



APPOSITION DES MISES EN GARDE RELATIVES À LA SÉCURITÉ D'UTILISATION

Il est impératif que les étiquettes de sécurité fournies avec le foyer soient collées à côté des dispositifs de contrôle du foyer. Une étiquette de sécurité doit être collée sur la plaque de l'interrupteur contrôlant l'allumage du foyer (voir **Figure A**) et, le cas échéant, sur le boîtier de la télécommande (**Figure B**). Pour achever l'installation correcte de ce foyer, procédez comme suit avec les étiquettes adhésives en langues étrangères fournies avec les instructions d'utilisation et d'entretien :

1. Repérez l'interrupteur qui contrôle le foyer (vérifiez que l'interrupteur contrôle le fonctionnement du foyer en le faisant basculer de Marche à Arrêt, et vice-versa). Nettoyez soigneusement la plaque murale de l'interrupteur pour éliminer la poussière et les traces de graisse ou d'huile. Collez l'étiquette sur la surface de la plaque de l'interrupteur mural qui contrôle le foyer (**Figure A**). Choisissez la langue qui est principalement parlée dans la résidence du propriétaire. En cas de doute, collez l'étiquette en anglais.
2. Si une télécommande est utilisée pour contrôler le foyer, nettoyez la soigneusement pour éliminer la poussière et les traces de graisse ou d'huile. Collez l'étiquette sur le boîtier de la télécommande (**Figure B**). Choisissez la langue qui est principalement parlée dans la résidence du propriétaire. En cas de doute, collez l'étiquette en anglais.
3. Si vous ne trouvez pas les étiquettes, veuillez appeler Innovative Hearth Products ou votre distributeur Innovative Hearth Products local pour recevoir gratuitement des étiquettes supplémentaires.

Étiquettes de remplacement, n° cat. H8024

Remarque : Le texte anglais est rouge sur un support transparent. Le texte français et espagnol est blanc sur un support noir.

DIAGRAMMES DES ÉTIQUETTES DE SÉCURITÉ



COLOCACIÓN DE ADVERTENCIAS DE SEGURIDAD EN OPERACIÓN

Se requiere que las etiquetas de instrucciones de seguridad incluidas con la chimenea se coloquen en el punto de operación y control de la misma. Se debe colocar una etiqueta de instrucciones de seguridad en la placa del interruptor de pared desde el cual se enciende y se apaga la chimenea (ver la **Figura A**) y en el transmisor de control remoto (**Figura B**) si se usa. Para completar correctamente la instalación de esta chimenea, encuentre las etiquetas adhesivas multilingües incluidas con las instrucciones de cuidado y operación y haga lo siguiente:

1. Identifique el interruptor de pared que controla la chimenea (verifique que el interruptor opera la chimenea encendiéndola y apagándola). Limpie bien la placa del interruptor de pared para quitar el polvo y aceite. Pegue la etiqueta en la superficie de la placa del interruptor que controla la chimenea (**Figura A**). Seleccione el idioma que más se habla en la casa. Si no sabe cuál es, use la etiqueta en inglés.
2. Si se usa un control remoto para controlar la chimenea, encuentre el transmisor y límpielo bien para quitar el polvo y aceite. Pegue la etiqueta en la superficie del transmisor (**Figura B**). Seleccione el idioma que más se habla en la casa. Si no sabe cuál es, use la etiqueta en inglés.
3. Si no puede encontrar las etiquetas, sírvase llamar a Innovative Hearth Products o al distribuidor de Innovative Hearth Products más cercano para recibir etiquetas de instrucciones de seguridad adicionales gratuitas.

Juego de etiquetas de repuesto - N° de cat. H8024

Nota: La etiqueta en inglés es transparente con texto rojo. Las etiquetas en francés y español son negras con texto blanco.

DIAGRAMAS DE ETIQUETAS DE SEGURIDAD



Illustrations are for example only. Your accessories may be different.

Les illustrations sont par exemple uniquement. Vos accessoires peuvent être différents.

Las ilustraciones son sólo ejemplos. Tu accesorios pueden ser diferentes.

Figure A



Figure B



GAS CONVERSION KITS

WARNING

This conversion kit shall be installed by a qualified service agency in accordance with the manufacturer's instructions and all applicable codes and requirements of the authority having jurisdiction. If the information in these instructions is not followed exactly, a fire, explosion or production of carbon monoxide may result causing property damage, personal injury or loss of life. The qualified service agency is responsible for the proper installation of this kit. The installation is not proper and complete until the operation of the converted appliance is checked as specified in the manufacturer's instructions supplied with the kit. The qualified service agency performing this installation assumes responsibility for this conversion.

AVERTISSEMENT

Cette trousse de conversion doit être installée par un technicien agréé, selon les instructions du fabricant et selon toutes les exigences et tous les codes pertinents de l'autorité compétente. Assurez-vous de bien suivre les instructions dans cette notice pour réduire au minimum le risque d'incendie, d'explosion ou la production de monoxyde de carbone pouvant causer des dommages matériels, des blessures ou la mort. Le technicien agréé est responsable de l'installation de cette trousse. L'installation n'est pas adéquate ni complète tant que le bon fonctionnement de l'appareil converti n'a pas été vérifié selon les instructions du fabricant fournies avec la trousse. Le fournisseur de service qualifié ayant réalisé l'installation assume les responsabilités liées à la conversion.

In Canada:

THE CONVERSION SHALL BE CARRIED OUT IN ACCORDANCE WITH THE REQUIREMENTS OF THE PROVINCIAL AUTHORITIES HAVING JURISDICTION AND IN ACCORDANCE WITH THE REQUIREMENTS OF THE CAN/CGA-B149.1 INSTALLATION CODE.

LA CONVERSION DEVRA ÊTRE EFFECTUÉE CONFORMÉMENT AUX RECOMMANDATIONS DES AUTORITÉS PROVINCIALES AYANT JURIDICTION ET CONFORMÉMENT AUX EXIGENCES DU CODE D'INSTALLATION CAN/CGA-B149.1.

Gas conversion kits are available to adapt your appliance from the use of one type of gas to the use of another. These kits contain all the necessary components needed to complete the task including labeling that must be affixed to ensure safe operation.

Kit part numbers are listed here and the following steps detail the conversion procedure. Refer to the instructions provided with the conversion kit when performing any gas conversion.

Natural to Propane Gas Conversion Kit

Unit Type	Cat. No.
Millivolt	H2198

INSTALLATION INSTRUCTIONS

Step 1. TURN OFF THE GAS SUPPLY TO THE APPLIANCE and disconnect power supply at the circuit breaker. Ensure appliance is cold.

CAUTION: THE GAS SUPPLY SHALL BE SHUT OFF PRIOR TO DISCONNECTING THE ELECTRICAL POWER, BEFORE PROCEEDING WITH THE CONVERSION.

ATTENTION: AVANT D'EFFECTUER LA CONVERSION, COUPEZ D'ABORD L'ALIMENTATION EN GAZ, ENSUITE, COUPEZ L'ALIMENTATION ÉLECTRIQUE.

The gas controls can be found behind the hinged drop-down panel.

Open the control compartment access panel, by lifting panel approximately 1/2" to disengage and swing the panel open from top.

On millivolt systems, the piezo igniter, Hi/Lo flame adjustment knob, and pilot and main gas ON/OFF control knob are located on the modesty panel. The gas valve is located behind the modesty panel. See **Figure 34 on Page 27**.

Remove the bottom compartment door by sliding the hinge pin, located at the door's left side, to the right until it disengages from the left corner post hole. Pull the door diagonally to the left, away from the fireplace.

Remove the modesty panel by pulling the bottom right corner of the modesty panel out slightly to disengage the snap-fit feature; lift the modesty panel by the tab on the panel's right end, pull the right end of the panel away from the cabinet and then pull the panel diagonally out of the left side cabinet panel slots. Remove the modesty panel carefully, so that none of the wires become loose or disconnected.

- d. Locate the latch at the top of the control compartment. To disengage the latch from the bottom vee-flange of the glass enclosure panel, reach for the handle located towards the back of the latch and pull the handle down toward the front of the unit. See **Figure 24** on **Page 21**.
- e. Swing the bottom of the door out and raise it slightly to lift the top flange of the door frame away from the appliance.

Step 2. Carefully remove the log set. **Exercise care as not to break the log set.**

Step 3. Referring to **Figure 29**, remove the burner.

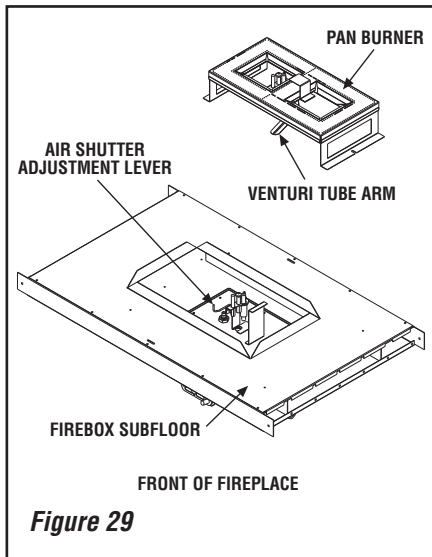

Figure 29

Millivolt Appliances

Step 4. Refer to **Figure 30** and the instructions provided with the kit. Using a Torx T20, remove and discard the three pressure regulator mounting screws. Remove the pressure regulator, spring, poppet, diaphragm and bushing. **Discard all removed components.** Ensure the rubber gasket installed on the back of the replacement pressure regulator is properly positioned and install the new pressure regulator using the new screws supplied with the kit. Tighten screws to 25 in-lbs of torque.

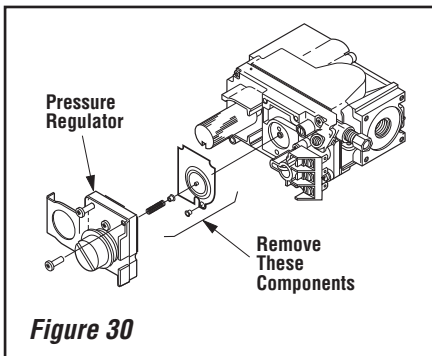

Figure 30

Step 5. Attach manometer to the manifold side pressure test fitting and verify manifold pressure reads 3.5" water column (0.87 kPa) for natural gas, and 10.0" water column (2.49 kPa) for propane gas.

Step 6. Refer to **Figure 31** and remove the pilot hood assembly to access the hexed pilot orifice. Remove and replace the orifice with the one provided with the kit.

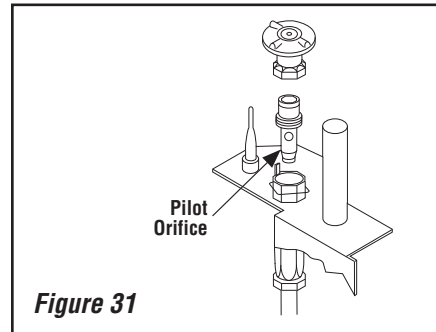

Figure 31

B. Install the burner as shown in **Figure 33**.

Ensure that the arm of the venturi of the burner is hooked onto the air shutter adjustment lever (refer to **Figure 29**). The primary air opening can be adjusted by rotating the adjustment lever from beneath the firebox floor. Refer to **Figure 26 on Page 22** for the recommended minimum primary air opening setting.

Burner Orifice Sizes (all models)		
Elevation Feet (meters)	Natural Gas drill size (inches)	Propane Gas** drill size (inches)
0-4500 (0-1372)	#32 (0.116") * 37L82 •	1.65mm (.065")** 74L88 •

** Standard size installed at factory
** If field converted.
• Part/Cat. Number*

Table 7

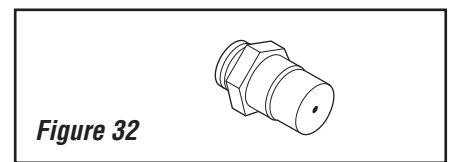

Figure 32

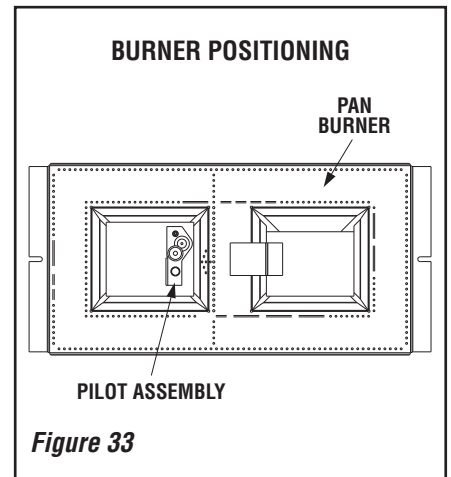

Figure 33

Step 9. Reassemble the remaining components by reversing the procedures outlined in the preceding steps.

Use pipe joint compound or Teflon tape on all pipe fittings before installing (ensure propane resistant compounds are used in propane applications, do not use pipe joint compounds on flare fittings).

Step 10. Attach the conversion label provided in the conversion kit to the rating plate on the appliance.

Step 11. Turn on gas supply and test for gas leaks.

ALWAYS TEST PRESSURE WITH THE VALVE REGULATOR CONTROL AT THE HIGHEST SETTING

OPERATION AND CARE OF YOUR APPLIANCE

WARNING

Young children should be carefully supervised when they are in the same room as the appliance. Toddlers, young children and others may be susceptible to accidental contact burns. A physical barrier is recommended if there are at risk individuals in the house. To restrict access to a fireplace or stove, install an adjustable safety gate to keep toddlers, young children and other at risk individuals out of the room and away from hot surfaces.

AVERTISSEMENT

Les jeunes enfants devraient être surveillés étroitement lorsqu'ils se trouvent dans la même pièce que l'appareil. Les tout petits, les jeunes enfants ou les adultes peuvent subir des brûlures s'ils viennent en contact avec la surface chaude. Il est recommandé d'installer une barrière physique si des personnes à risques habitent la maison. Pour empêcher l'accès à un foyer ou à un poêle, installez une barrière de sécurité; cette mesure empêchera les tout petits, les jeunes enfants et toute autre personne à risque d'avoir accès à la pièce et aux surfaces chaudes.

Gas Controls/Control Compartment Access

The gas controls can be found behind the hinged drop-down panel.

Open the control compartment access panel, by lifting panel approximately 1/2" to disengage and swing the panel open from top.

On millivolt systems, the piezo igniter, Hi/Lo flame adjustment knob, and pilot and main gas ON/OFF control knob are located on the modesty panel. The gas valve is located behind the modesty panel. See **Figure 34**.

Remove the bottom compartment door by sliding the hinge pin, located at the door's left side, to the right until it disengages from the left corner post hole. Pull the door diagonally to the left, away from the fireplace.

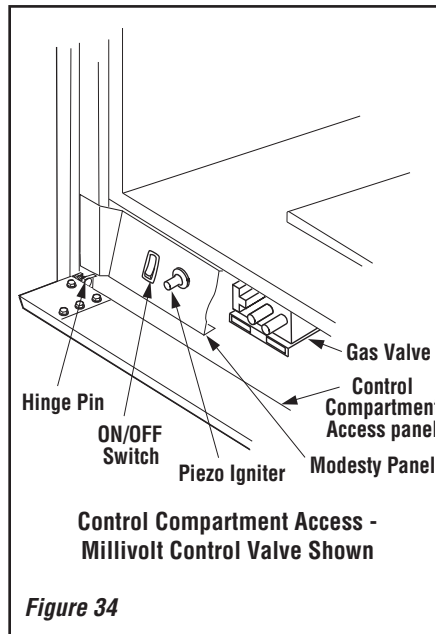

Refer to **Figure 34** for access to the gas control valve. Millivolt appliances will be fitted with the gas control valve shown in **Figure 35**.

Millivolt Appliances -

To light millivolt appliances refer to the detailed lighting instructions found on **Page 45 (English) and Page 46 (French)**. Millivolt appliance lighting instructions may also be found on the pull out lighting instruction labels attached to the gas control valve.

Millivolt appliances are fitted with an ON/OFF Rocker Switch for appliance ON/OFF control. Refer to **Figure 34** for its location. Once the pilot is lighted, the ON/OFF rocker switch will control the appliance ON/OFF operation. To operate: Toggle the switch between its ON and OFF positions.

If your millivolt appliance is equipped with an optional remote wall switch or remote control kit and the pilot is lit, the appliance main burner may be turned on and off with the wall switch or remote control.

IMPORTANT SAFETY INFORMATION

Important Safety Information

1. **WARNING: Do not operate appliance with the glass front removed, cracked or broken.**
2. **Do not use this appliance if any part has been under water. Immediately call a qualified service technician to inspect the appliance and to replace any part of the control system and any gas control which has been under water.**
3. **Due to high temperatures, the appliance should be located out of traffic and away from furniture and draperies.**
4. **Children and adults should be alerted to the hazards of high surface temperature and should stay away to avoid burns or clothing ignition.**
5. **Clothing or other flammable material should not be placed on or near the appliance.**
6. **Young children should be carefully supervised when they are in the same room as the appliance. Toddlers, young children, and others may be susceptible to accidental contact burns. A physical barrier is recommended if there are at-risk individuals in the house. To restrict access to a fireplace or stove, install an adjustable safety gate to keep toddlers, young children, and other at-risk individuals out of the room and away from hot surfaces.**
7. **Any safety screen, guard or barrier removed for servicing an appliance must be replaced prior to operating the appliance.**
8. **Installation and repair should be done by a qualified service person. The appliance should be inspected before use and at least annually by a professional service person. More frequent cleaning may be required due to excessive lint from carpeting, bedding material, et cetera. It is imperative that control compartments, burners, and circulating air passageways of the appliance be kept clean. See maintenance instructions on *Page 34*.**

L'information de sûreté importante

1. **AVERTISSEMENT. Ne pas utiliser l'appareil si le panneau frontal en verre n'est pas en place, est craqué ou brisé.**
2. **Ne pas se servir de cet appareil s'il a été plongé dans l'eau, même partiellement. Faire inspecter l'appareil par un technicien qualifié et remplacer toute partie du système de contrôle et toute commande qui ont été plongées dans l'eau.**
3. **En raison des températures élevées, l'appareil devrait être installé dans un endroit où il y a peu de circulation et loin du mobilier et des tentures.**
4. **Les enfants et les adultes devraient être informés des dangers que posent les températures de surface élevées et se tenir à distance afin d'éviter des brûlures ou que leurs vêtements ne s'enflamment.**
5. **On ne devrait pas placer de vêtements ni d'autres matières inflammables sur l'appareil ni à proximité.**
6. **Les jeunes enfants devraient être surveillés étroitement lorsqu'ils se trouvent dans la même pièce que l'appareil. Les tout petits, les jeunes enfants ou les adultes peuvent subir des brûlures s'ils viennent en contact avec la surface chaude. Il est recommandé d'installer une barrière physique si des personnes à risques habitent la maison. Pour empêcher l'accès à un foyer ou à un poêle, installez une barrière de sécurité ; cette mesure empêchera les tout petits, les jeunes enfants et toute autre personne à risque d'avoir accès à la pièce et aux surfaces chaudes.**
7. **Tout écran ou protecteur retiré pour permettre l'entretien de l'appareil doit être remis en place avant de mettre l'appareil en marche.**
8. **L'installation et la réparation devrait être confiées à un technicien qualifié. L'appareil devrait faire l'objet d'une inspection par un technicien professionnel avant d'être utilisé et au moins une fois l'an par la suite. Des nettoyages plus fréquents peuvent être nécessaires si les tapis, la literie, et cetera produisent une quantité importante de poussière. Il est essentiel que les compartiments abritant les commandes, les brûleurs et les conduits de circulation d'air de l'appareil soient tenus propres. Voyez les instructions d'entretien à la *Page 34*.**

Información importante de seguridad

1. **ADVERTENCIA: No opere el artefacto con el frente de vidrio quitado, agrietado o roto.**
2. **No use este artefacto si alguna de sus partes ha estado bajo agua. Llame de inmediato a un técnico de servicio calificado para que inspeccione el artefacto y reemplace cualquier parte del sistema de control y cualquier control de gas que haya estado bajo agua.**
3. **Debido a las altas temperaturas, el artefacto debe situarse fuera de las áreas de tráfico y lejos del mobiliario y cortinas.**
4. **Se debe alertar a los niños y adultos sobre los peligros de las altas temperaturas en la superficie y que se mantengan alejados para evitar quemaduras o ignición de la ropa.**
5. **No debe colocarse ropa u otros materiales inflamables sobre y cerca del artefacto.**
6. **Se debe supervisar de cerca a los niños cuando estén en el mismo cuarto que el artefacto. Los niños pequeños, los jóvenes y otras personas pueden ser susceptibles a quemaduras por contacto accidental. Se recomienda instalar una barrera física si hay personas en riesgo en la casa. Para restringir el acceso a una chimenea o estufa, instale una puerta de seguridad ajustable para mantener a los niños pequeños, jóvenes y otras personas en riesgo fuera del cuarto y lejos de las superficies calientes.**
7. **Cualquier malla o resguardo de seguridad quitado para dar servicio a un artefacto, debe reinstalarse antes de operar el artefacto.**
8. **Una persona de servicio competente debe realizar la instalación y reparación. Una persona de servicio profesional debe inspeccionar el artefacto antes de usar al menos una vez por año. Se puede requerir limpieza más frecuente debido a la pelusa excesiva del alfombrado, del material de cobijas, etc. Es imprescindible mantener limpios los compartimientos de control, los quemadores y los pasajes de circulación del aire del artefacto. Ver las instrucciones de mantenimiento en la *página 34*.**

HOMEOWNER'S INSTRUCTIONS - ATTACHING SAFETY IN OPERATION WARNINGS

ATTACHING SAFETY IN OPERATION WARNINGS

Your fireplace has been furnished with safety instruction labels that are to be affixed to the operation and control point of the fireplace. A safety instruction label should be affixed to the wall switch plate where the fireplace is turned on and off (*See Figure A*) and if used on the remote control handheld transmitter (*Figure B*). The warnings should already have been put in place when the fireplace initial set-up was completed. If they are not affixed at these spots, locate the multi-lingual adhesive labels provided with these instructions and proceed as follows:

1. Locate the wall switch that controls the fireplace (verify the switch operates the fireplace by turning it on and off). Clean the wall switch plate thoroughly to remove any dust and oils. Affix the label to the surface of the plate of the wall switch that controls the fireplace (*Figure A*). Choose the language primarily spoken in the home.
2. If a remote control is used to control the fireplace, locate the transmitter and clean it thoroughly to remove any dust and oils. Affix the label to the surface of handheld transmitter (*Figure B*). Choose the language primarily spoken in the home.
3. If you are unable to locate the labels, please call Lennox Hearth Products or your nearest Lennox Hearth Products dealer to receive additional safety instruction labels free of charge.

Cat. No. H8024 Replacement Label Kit

NOTE: English is red text on clear label. French and Spanish are white text on black label.

SAFETY LABEL DIAGRAMS



APPOSITION DES MISES EN GARDE RELATIVES À LA SÉCURITÉ D'UTILISATION

Votre foyer a été livré avec des étiquettes de sécurité qui doivent être collées à côté des dispositifs de contrôle du foyer. Une étiquette de sécurité devrait être collée sur la plaque de l'interrupteur contrôlant l'allumage du foyer (*voir Figure A*) et, le cas échéant, sur le boîtier de la télécommande (*Figure B*). Les mises en garde auraient dû être collées au moment de l'installation initiale du foyer. Si ce n'est pas le cas, prenez les étiquettes adhésives multilingues fournies avec ces instructions et procédez comme suit:

1. Repérez l'interrupteur qui contrôle le foyer (vérifiez que l'interrupteur contrôle le fonctionnement du foyer en le faisant basculer de Marche à Arrêt, et vice-versa). Nettoyez soigneusement la plaque murale de l'interrupteur pour éliminer la poussière et les traces de graisse ou d'huile. Collez l'étiquette sur la surface de la plaque de l'interrupteur mural qui contrôle le foyer (*Figure A*). Choisissez la langue qui est principalement parlée dans la résidence du propriétaire.
2. Si une télécommande est utilisée pour contrôler le foyer, nettoyez la soigneusement pour éliminer la poussière et les traces de graisse ou d'huile. Collez l'étiquette sur le boîtier de la télécommande (*Figure B*). Choisissez la langue qui est principalement parlée dans la résidence du propriétaire.
3. Si vous ne trouvez pas les étiquettes, veuillez appeler Lennox Hearth Products ou votre distributeur Lennox Hearth Products local pour recevoir gratuitement des étiquettes supplémentaires.

Étiquettes de remplacement, n° cat. H8024

Remarque : Le texte anglais est rouge sur un support transparent. Le texte français et espagnol est blanc sur un support noir.

DIAGRAMMES DES ÉTIQUETTES DE SÉCURITÉ



COLOCACIÓN DE ADVERTENCIAS DE SEGURIDAD EN OPERACIÓN

Su chimenea incluye etiquetas de instrucciones de seguridad que deben colocarse en el punto de operación y control de la chimenea. Se debe colocar una etiqueta de instrucciones de seguridad en la placa del interruptor de pared desde el cual se enciende y se apaga la chimenea (*ver la Figura A*) y en el transmisor de control remoto (*Figura B*) si se usa. Las advertencias ya deben haberse colocado cuando se completó la instalación inicial de la chimenea. Si no están colocadas en estos lugares, encuentre las etiquetas adhesivas multilingües proporcionadas con estas instrucciones y prosiga de la siguiente manera:

1. Identifique el interruptor de pared que controla la chimenea (verifique que el interruptor opera la chimenea encendiéndola y apagándola). Limpie bien la placa del interruptor de pared para quitar el polvo y aceite. Pegue la etiqueta en la superficie de la placa del interruptor que controla la chimenea (*Figura A*). Seleccione el idioma que más se habla en la casa.
2. Si se usa un control remoto para controlar la chimenea, encuentre el transmisor y límpielo bien para quitar el polvo y aceite. Pegue la etiqueta en la superficie del transmisor (*Figura B*). Seleccione el idioma que más se habla en la casa.
3. Si no puede encontrar las etiquetas, sírvase llamar a Lennox Hearth Products o al distribuidor de Lennox Hearth Products más cercano para recibir etiquetas de instrucciones de seguridad adicionales gratuitas.

Juego de etiquetas de repuesto - N° de cat. H8024

Nota: La etiqueta en inglés es transparente con texto rojo. Las etiquetas en francés y español son negras con texto blanco.

DIAGRAMAS DE ETIQUETAS DE SEGURIDAD



Illustrations are for example only. Your accessories may be different.

Les illustrations sont par exemple uniquement. Vos accessoires peuvent être différents.

Las ilustraciones son sólo ejemplos. Tu accesorios pueden ser diferentes.

Figure A



Figure B



APPLIANCE INSTALLATION, SERVICE, AND MAINTENANCE NOTICES

WARNING: Improper installation, adjustment, alteration, service or maintenance can cause injury or property damage. Refer to the owner's information manual provided with this appliance. For assistance or additional information consult a qualified installer, service agency or the gas supplier.

AVERTISSEMENT : Une installation, un réglage, une modification, une réparation ou un entretien mal effectué peut causer des dommages matériels ou des blessures. Voir la notice de l'utilisateur qui accompagne l'appareil. Pour de l'aide ou des renseignements supplémentaires, consultez un installateur, un technicien agréé ou le fournisseur de gaz.

Only trim kit(s) supplied by the manufacturer shall be used in the installation of this appliance.

Seules les trousse de garniture fournies par le fabricant doivent être utilisées pour l'installation de cet appareil.

These appliances must not be connected to a chimney or flue serving a separate solid fuel burning appliance.

Draft relief openings must not be covered or blocked.

Any change to this appliance and/or its operating controls is dangerous. Improper installation or use of this appliance can cause serious injury or death from fire, burns, explosion or carbon monoxide poisoning.

CARBON MONOXIDE POISONING: Early signs of carbon monoxide poisoning are similar to the flu with headaches, dizziness and/or nausea. If you have these signs, obtain fresh air immediately. Turn off the gas supply to the appliance and have it serviced by a qualified professional, as it may not be operating correctly. Some people are more affected by carbon monoxide than others, including pregnant women, people with heart or lung disease or anemia, those under the influence of alcohol, and those at high altitudes.

Turn off gas and electrical power to the fireplace and allow it to cool before cleaning or servicing the appliance.

APPLIANCE OPERATION NOTICES

Do not operate appliance with the glass front removed, cracked, or broken.

These fireplaces are vented gas appliances. Do not burn wood or other material in these appliances.

This appliance is only for use with the type of gas indicated on rating plate. This appliance is not convertible for use with other gases, unless a certified kit is used.

These appliances are designed to operate on natural gas or propane gas only. The use of other fuels or combinations of fuels will degrade the performance of this system and may be dangerous.

Cet appareil doit être utilisé uniquement avec les types de gaz indiqués sur la plaque signalétique. Ne pas l'utiliser avec d'autres gaz sauf si un kit de conversion certifié est installé.

Provide adequate clearances around air openings and adequate accessibility clearance for service and proper operation. Never obstruct the front or back openings of the appliance.

Do not use this appliance if any part has been under water. Immediately call a qualified service technician to inspect the appliance and to replace any part of the control system and any gas control that has been under water.

These fireplaces are designed as decorative appliances and are not intended for use as areas. They must not be equipped with wall thermostats or remote controls with thermostat functions.

CAUTION: Hot while in operation. Do not touch. Severe Burns may result. Keep children, clothing furniture, gasoline and other liquids having flammable vapors away.

ATTENTION : L'appareil est chaud lorsqu'il fonctionne. Ne pas toucher l'appareil. Risque de brûlures graves. Surveiller les enfants. Garder les vêtements, les meubles, l'essence ou autres liquides produisant des vapeurs inflammables loin de l'appareil.

This appliance uses room air for combustion. It is imperative that provisions for adequate combustion and ventilation air be made. This appliance is NOT designed to and will not operate in a negative pressure. Contact your dealer if you suspect such a situation exists.

WARRANTY INFORMATION

Your gas appliance is covered by a limited lifetime warranty. You will find a copy of the warranty accompanying this manual. Please read the warranty to be familiar with its coverage.

Retain this manual. File it with your other documents for future reference.

Failure to comply with the installation and operating instructions provided will result in an improperly installed and operating appliance, voiding its warranty.

Do not attempt to alter or modify the construction of the appliance or its components. Any modification or alteration may void the warranty, certification, and listings of this unit.

NEGATIVE PRESSURE WARNING

WARNING

B-Vent appliances are not designed to operate in negatively pressured environments (pressure within the home is less than pressures outside). Significant negatively pressured environments caused by weather, home design, or other devices may impact the operation of these appliances. Negative pressures may result in poor flame appearance, sooting, damage to property and/or severe personal injury. Do not operate these appliances in negatively pressured environments.

General Information

The fireplace models covered in this manual are b-vented decorative fireplaces designed for residential application.

The *Millivolt* appliances have a millivolt gas control valve with piezo ignition system. If any optional accessories which require electrical power are being installed, the electrical power must be provided at the time of appliance installation.

These appliances comply with National Safety Standards and are tested and listed by PFS (Report No. 14-172) to ANSI Z21.50 (in Canada, CSA-2.22), and CAN/CGA-2.17-M91, latest editions, in both USA and Canada, as vented gas fireplaces.

The Installation must conform to local codes or, in the absence of local codes, with the National Fuel Gas Code, ANSI Z223.1/NFPA 54-latest edition, or the Natural Gas and Propane Installation Code, CAN/CGA B149.1-latest edition. The appliance, when installed, must be electrically grounded in accordance with local codes or, in the absence of local codes, the latest edition of the National Electrical Code, ANSI/NFPA 70, or the Canadian Electrical Code, CSA C22.1 - latest editions.

BTU Input

Millivolt Models - The millivolt appliances are manually controlled and feature a spark igniter (piezo) that allows the appliance's pilot gas to be lit without the use of matches or batteries. This system provides continued service in the event of a power outage.

Millivolt models come standard with a manually-modulated gas valve; flame appearance and heat output can be controlled at the gas valve. The BTU Input for these appliances is shown in **Table 8**.

Input (BTU) Gas Valves (all models)		
All Models	Fuel Type	Input Rate (BTU / HR)
Millivolt	Natural	37,500 high 30,000 low
Millivolt	Propane	34,000 high 27,000 low

Table 8

Gas Pressure - All Models

Tables 9 and 10 show the appliances' inlet and manifold gas pressure requirements:

Inlet Gas Supply Pressure (all models)		
Fuel #	Minimum	Maximum
Natural Gas	4.5" WC (1.12 kPa)	10.5" WC (2.62 kPa)
Propane**	11.0" WC (2.74 kPa)	13.0" WC (3.24 kPa)

Table 9 **If field converted.

Manifold Gas Supply Pressure (all models)		
Fuel #	Low	High
Natural Gas	2.2" WC (0.55 kPa)	3.5" WC (0.87 kPa)
Propane**	6.3" WC (1.57 kPa)	10.0" WC (2.49 kPa)

Table 10 **If field converted.

The appliance and its appliance main gas valve must be disconnected from the gas supply piping system during any pressure testing of that system at test pressures in excess of 1/2 psi (3.5 kPa).

The appliance must be isolated from the gas supply piping system by closing its equipment shutoff valve during any pressure testing of the gas supply piping system at test pressures equal to or less than 1/2 psi (3.5 kPa).

Orifice Sizes - Sea Level to High Altitude (All Models)

These appliances are tested and approved for installation at elevations of 0-4500 feet (0-1372 meters) above sea level using the standard burner orifice sizes (marked with an "*" in **Table**). For elevations above 4500 feet, contact your gas supplier or qualified service technician.

Deration - At higher elevations, the amount of BTU fuel value delivered must be reduced by either using gas that has been derated by the gas company or by changing the burner orifice to a smaller size as regulated by the local authorities having jurisdiction and by the (USA) National Fuel Gas Code NFPA 54/ANSI Z223.1 - latest edition or, in Canada, the CAN/CGA-B149.1 codes - latest edition.

Install the appliance according to the regulations of the local authorities having jurisdiction and, in the USA, the National Fuel Gas Code NFPA 54 / ANSI Z223.1 - latest edition or, in Canada, the CAN/CGA-B149.1 - latest edition.

Flame breadth, height and width will diminish 4% for every 1,000 feet of altitude.

Burner Orifice Sizes (all models)		
Elevation Feet (meters)	Natural Gas drill size (inches)	Propane Gas** drill size (inches)
0-4500 (0-1372)	#32 (0.116") * 37L82 •	1.65mm (.065")** 74L88 •

Table 11 * Standard size installed at factory
 **If field converted.
 • Part/Cat. Number

In Canada - CAN/CGA-2.17-M91 (R2009)(high altitude): THE CONVERSION SHALL BE CARRIED OUT BY A MANUFACTURER'S AUTHORIZED REPRESENTATIVE, IN ACCORDANCE WITH THE REQUIREMENTS OF THE MANUFACTURER, PROVINCIAL OR TERRITORIAL AUTHORITIES HAVING JURISDICTION AND IN ACCORDANCE WITH THE REQUIREMENTS OF THE CAN/CGA-B149.1 OR CAN/CGA-B149.2 INSTALLATION CODES.

Burn-in Period

During the first few fires of this appliance there will be some odor due to the curing of the paint and burning off of lubricants used in the manufacturing process. Depending on your use, the burn-in period may take a few hours or a few days.

KEEP YOUR HOUSE WELL VENTILATED DURING THE CURING PROCESS. THE ODOR AND HAZE EMITTED DURING THE CURING PROCESS CAN BE QUITE NOTICEABLE AND MAY SET OFF A SMOKE DETECTOR.

A white film may develop on the glass front during the first few fires as part of the curing process. The glass should be kept clean during the first two weeks of use to prevent the film from baking on (making it very difficult to remove). See **Cleaning Glass** on **Page 34**.

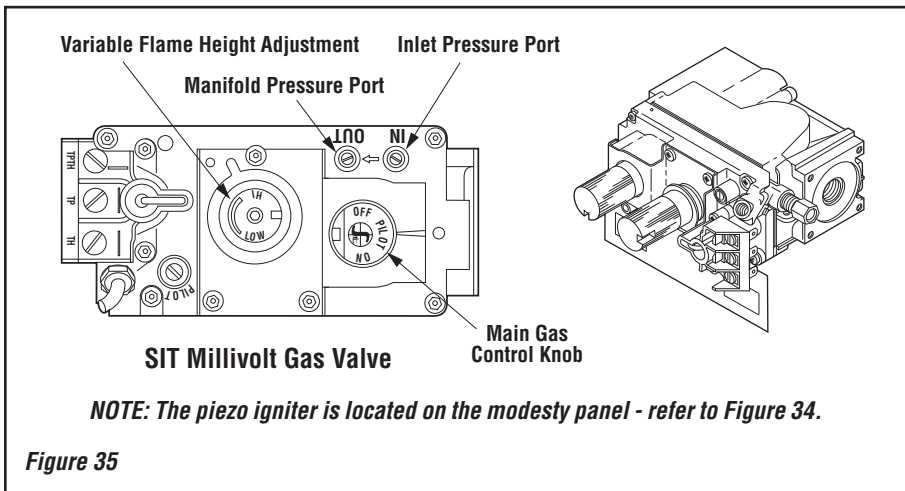

Figure 35

**Variable Flame Height Adjustment
 (Millivolt Appliances only)**

All Millivolt appliances are equipped with a variable gas control valve. Flame height for these models may be adjusted through a range between fixed low and high settings, alternately, while the appliance is in operation.

Adjust the flame height as desired after lighting the appliance by rotating the variable adjustment control knob located on the front of the valve (refer to Figure 35). (An extension is provided to this knob so that the adjustment may be made at the modesty panel).

Outside Combustion Air Controls

Many appliances are equipped, when installed, with an outside (make-up air) vent system that is designed to provide the appliance with outside make-up air for combustion when in operation. The outside air control lever for the outside air system is standard on all appliances but should not be operated if the complete system is not installed. Refer to **Figure 36**. When the complete outside air vent system is installed, the installer will remove the securing screw from the combustion air control lever located on the right side of the fireplace opening.

If the securing screw has not been removed and you have reason to believe that you have a complete outside air system, contact your distributor to have your appliance inspected for the presence of the complete system. DO NOT assume that you have this system in place.

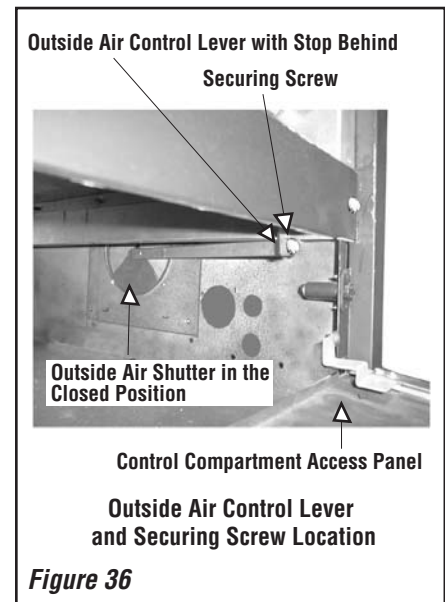

Figure 36

! WARNING

Do not operate the shutoff lever unless a complete outside combustion air system has been installed with your appliance.

To open the outside air shutter, open the bottom control access panel, reach into the gap between the firebox bottom and the modesty panel, and pull the outside air control lever all the way out. The outside air shutter should be fully open when the fireplace is in use and completely closed when the fireplace is not being used. Closing it when not in use will prevent outside cold air from entering the dwelling.

Venting Action and Safety Limit Operation

If you suspect that the appliance is not venting properly, or you notice windows fogging or sweating, you may want to conduct the following spillage test:

- 1 - Place unit in its normally-operated condition, that is, with the glass enclosure panels in place.
- 2 - Close all doors and windows in the room. Turn on all exhaust fans in the house.
- 3 - Light the appliance.
- 4 - Wait 15 minutes.
- 5 - To check for venting action, start by holding a smoke producing device within an inch of one edge (side edge, not top or bottom edge) of one glass enclosure panel. The smoke should be drawn toward the edge of the glass enclosure panel. Continue the test by moving the smoke producing device along the entire length of both side-edges of the glass door. Repeat the test for all glass enclosure panels.
- 6 - **If the smoke is not drawn towards the edges of the glass door turn off the appliance and call a qualified service technician.**

Manual-Reset Safety Limit Switch

This appliance is equipped with a manual-reset blocked flue safety limit switch. Refer to **Figure 37** for its location. If, during appliance operation, the flame goes out (independently of the burner on/off wall switch), it may be due to the operation of this safety limit switch. **First allow the appliance to cool**, then reset the safety switch by pushing the red reset button on it.

A - To access the blocked flue safety switch:

- 1 - Remove the hood by pulling straight out from the unit. Remove the front face assembly by pulling up approximately 1/2" and away from unit.
- 2 - Reach between the cabinet side and the firebox side wall and locate the blocked flue safety switch.
- 3 - Push the red reset button on the switch.

The appliance should then relight and remain lit. If this does not occur, **turn off the appliance and call a qualified service technician.**

B - To access the blocked flue safety switch:

NOTE: This procedure should only be performed by a qualified service technician.

- 1 - Lower bottom hinged panel on the control side of the fireplace. Remove the glass enclosure panel as described on **Page 35**.
- 2 - Remove the side baffle securing screws (5) and then remove the baffle.
- 3 - Remove the safety switch bracket securing screws (2), and pull the switch/bracket assembly through the side panel slot.
- 4 - Push the red reset button on the switch.
- 5 - Reinstall the switch/bracket assembly.
- 6 - Reinstall the side baffle.
- 7 - Reinstall front glass door and front face assembly with barrier.
- 8 - Reinstall the hood.

The appliance should then relight and remain lit. If this does not occur, check unit for a blocked flue condition.

NOTE: Front Face Assembly with barrier installed must be reinstalled prior to operation.

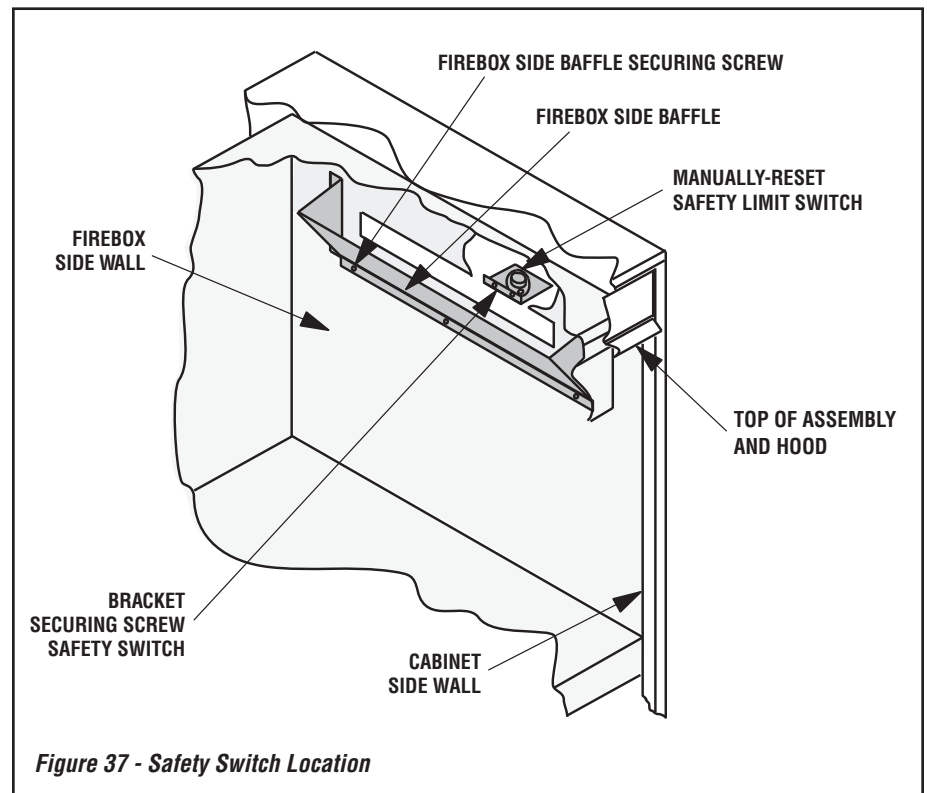

Figure 37 - Safety Switch Location

MAINTENANCE

(See Maintenance Schedule, Page 44)

Refer to the maintenance schedule for maintenance tasks, procedures, periodicity and by whom they should be performed. Always verify proper operation of the appliance after servicing.

WARNING

Turn off gas and electrical power to the fireplace and allow it to cool before cleaning or servicing the appliance.

CAUTION: Wear gloves and safety glasses for protection while doing required maintenance.

Verify proper operation after servicing.

S'assurer que l'appareil fonctionne adéquatement une fois l'entretien terminé.

Always turn off gas to the pilot (millivolt appliances) before cleaning. Before re-lighting, refer to the lighting instructions in this manual. Instructions are also found on a pull-out panel located in the control compartment.

Always keep the appliance area clear and free from combustible materials, gasoline and other flammable vapors and liquids.

Inspect Venting System

The appliance and venting system should be thoroughly inspected before initial use and at least annually by a qualified service technician (inspection should include ensuring that venting system is unobstructed and vent components are properly assembled and not damaged). **Homeowner must contact a qualified service technician at once if any abnormal condition is observed.**

If the venting system is disassembled for any reason, a qualified service technician should follow vent installation instructions for proper reassembly and proper sealing of the venting system components. However, more frequent periodic inspections and cleanings should be performed by the homeowner.

Cleaning Glass

(see *Front Glass Enclosure Panel, Removal and Installation* on **Page 35**).

NOTE: Clean glass after first two weeks of operation (after *Burn-In* period is over) and then only when necessary and when the fireplace is cool. Wipe surface with a clean, dampened, soft cloth. Follow with a dry, soft towel as desired. Take care not to scratch the glass surface.

IMPORTANT: Do not use abrasive cleaners on glass. Never clean the glass when it is hot.

The viewing glass should be cleaned periodically to remove any build-up caused from the following:

- During start-up, it is normal for condensation to form on the inside of the glass (this condensation and fog will usually disappear in a few minutes). The moisture can cause lint, dust and other airborne particles to cling to the glass surface.
- Initial curing of the high temperature paint and burning off of lubricants used in the manufacturing process may result in a film on the glass.
- A white coating may form on the glass as a result of impurities and minerals in the fuel.

It is recommended that the glass be cleaned two or three times during each year, depending on the circumstances present. The following cleaning solutions are approved for use to clean glass:

- Non-ammonia based household cleaner
- 50%-50% mix of white vinegar and water
- Gas fireplace/stove glass cleaner

Inspect Glass Gasket - Visually inspect the gasket on the backside of the glass enclosure panels. The gasket surface must be clean, free of irregularities and seated firmly.

Clean Control Compartment

Keep control compartment clean by vacuuming or brushing at least twice a year. More frequent cleaning may be required due to excessive lint from carpeting, bedding materials, etc. It is important that control compartments, burners and circulating air passageways of the appliance be kept clean.

Clean Logs And Burner

Carefully remove the logs (use care when handling the fiber logs, as they become quite fragile after curing). Vacuum out any foreign matter (lint, carbon, etc.) on the burner. Ensure the burner ports are "open." Remove any carbon deposits from the under side of the logs using a vacuum cleaner, or a soft bristled brush (i.e. paint brush).

NOTE: Improper positioning of logs can create carbon build-up and will alter the performance of the appliance.

Replacing Logs

If the logs become damaged by accident or improper handling and need replacement, use only the proper replacement logs from manufacturer (see **Pages 48 and 49** for ordering information).

Re-Install Embers and Logs

Carefully follow placement instructions on **Pages 36 through 38**. All logs should fit onto corresponding pins and/or log stoppers. This will ensure a proper flame and safe combustion.

Inspect Wiring

Refer to wiring diagrams on **Page 41**.

CAUTION: Label all wires prior to disconnection when servicing controls. Wiring errors can cause improper and dangerous operation. Verify proper operation after servicing.

ATTENTION: Au moment de l'entretien des commandes, étiquetez tous les fils avant de les débrancher. Des erreurs de câblage peuvent entraîner un fonctionnement inadéquat et dangereux.

Inspect and clean all wire connections. Ensure that there is no melting or damage. Inspection should include:

- Terminals at the Valve
- OFF/ON Switch
- (Optional Control Switch) Remote Control or Remote Wall Switch Kit

Inspect Burner Flame and Pilot Flame Appearance

Periodically do a visual check of the burner flame and the pilot flame. Ensure that the burner flame appearance resembles the flame shown in **Figure 43** and as described in *flame Appearance and Sooting* on **Page 39**. Contact a qualified service technician at once if any abnormal condition is observed.

Small Area Paint Touch-up

Only use a factory supplied paint kit for touch-ups. Paint is available at your local Innovative Hearth Products dealer. Never attempt to paint a hot fireplace.

Do not attempt to repaint the appliance until the finish is completely cured (see *Burn-In Period* on **Page 31**). If the surface later becomes stained or marred, it may be lightly sanded and touched up with spray paint.

Front Glass Enclosure Panel, Removal and Installation

! WARNING

- Do not attempt to substitute the materials used on these doors, or replace cracked or broken glass.
- Handle this glass with extreme care! Glass is susceptible to damage – Do not scratch or handle roughly while reinstalling the glass door frame.
- The glass door(s) of this appliance must only be replaced as a complete unit as provided by the manufacturer. Do not attempt to replace broken, cracked or chipped glass separately.
- Do not attempt to touch the front enclosure glass with your hands while the fireplace is in use.
- DO NOT abuse glass door by striking or slamming shut.

! WARNING

The door should easily close without needing to be pressed down. If it has to be pressed down to close, the gasket in the top of the door should be dressed so it lays on the glass.

! WARNING

Do not operate appliance with the glass front removed, cracked or broken.

! AVERTISSEMENT

Ne pas utiliser l'appareil si le panneau frontal en verre n'est pas en place, est craqué ou brisé.

! WARNING

Any safety screen or guard removed for servicing the appliance must be replaced prior to operating the appliance.

! AVERTISSEMENT

Tout écran ou protecteur retiré pour permettre l'entretien de l'appareil doit être remis en place avant de mettre l'appareil en marche.

Only doors certified with the appliance shall be used.

Seules des portes certifiées pour cet appareil doivent être utilisées.

WARNING: DO NOT abuse glass door by striking or slamming shut.

These are B-vent appliances. They are designed to operate only when the glass enclosure panels are installed. Generally the glass enclosure panels should not be removed except to gain access to the components within the firebox.

Removing Glass Enclosure Panels (see Figure 38)

To access the glass door securing latches, first remove the hood by pulling firmly straight away from the unit. Remove the front face assembly by lifting up top and bottom evenly approximately 1/2" and pulling straight out from the unit once the brackets are disengaged.

Remove the bottom compartment door by sliding the hinge pin, located at the door's left side, to the right until it disengages from the left corner post hole. Pull the door diagonally to the left, away from the fireplace.

Locate the latch at the top of the control compartment and disengage them from the door frame bottom vee-flange, pulling down on its handle to open it.

Installing Glass Enclosure Panel (see Figure 38)

Retrieve the glass door. Visually inspect the gasket on the backside of the frame. Gasket surface must be clean, free of irregularities and seated firmly.

Position the door in front of the firebox opening with the bottom of the door held away from the fireplace (Figure 38). Hook the top flange of the door frame over the top of the firebox frame.

Let the bottom of the door frame swing gently in towards the fireplace ensuring that the gasket seats evenly as the door frame draws shut. Fasten the latch located underneath the firebox floor to the door's vee-flange. Close both the latch securely.

NOTE: Front Face Assembly with barrier installed must be reinstalled prior to operation.

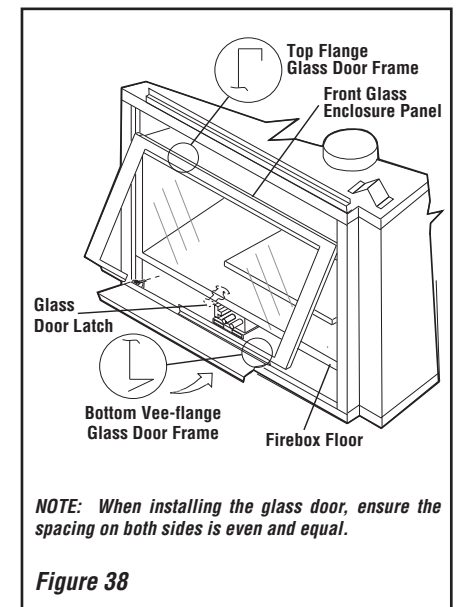

Figure 38

INSTALL VERMICULITE, GLOWING EMBERS AND LOGS

NOTE: It is important to ensure proper log placement per the manual when installing these units. Verify pilot flame is not obstructed. See Verifying Appliance Operation on **Page 17**.

NOTE: Turn off all electricity to the appliance before you install vermiculite, embers and logs. **DO NOT** attempt to install the logs until the appliance installation has been completed, the gas line connected and tested for leaks and the initial burner operation has been checked out.

INSTALLATION STEPS:

READ WARNINGS ON THIS PAGE BEFORE PROCEEDING. FOLLOW THE LOG PLACEMENT INSTRUCTIONS EXACTLY

1. **Remove the front glass enclosure panel** (see *Glass Enclosure Panel Removal and Installation Instructions, Page 35*).
2. **Remove the following from firebox:** log set, bag of embers and bag of vermiculite. **Handle logs carefully to prevent breakage.**
3. **Ensure the Grate is properly installed** in the firebox with the 4 legs of the grate fitting into the 4 dimples on the firebox floor.
4. **Placement of Glowing Embers -**
 Separate the Embers (rockwool) into pieces about the size of a quarter (see **Figure 39**). Keep the pieces fluffed up, not matted. Distribute these pieces over the surface of the burner, as shown in **Figure 40**. Do not use more than is necessary. Ensure that the main burner ports remain uncovered by the ember material.
5. **Place Volcanic Stone -** Spread volcanic stone evenly over firebox floor.
6. **Install Vermiculite -** Place some vermiculite on the firebox floor around the grate (the entire bag of vermiculite will NOT be used). **DO NOT PLACE ANY VERMICULITE ON THE BURNER.**

NOTE: This appliance is provided with enough Glowing Embers for several applications, do not use all that is in a new bag at one time. For best glowing effect, replace the ember material annually. Replacement Glowing Embers are available (order Catalog Number 88L53).

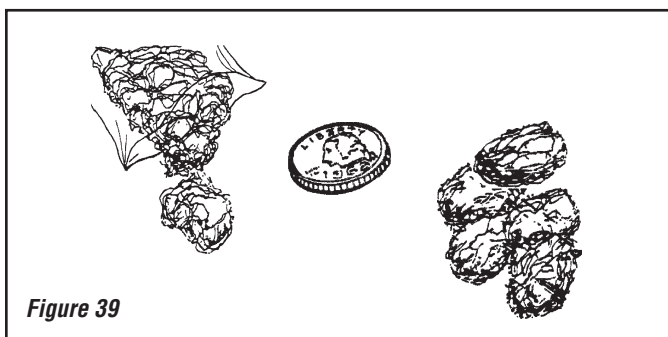

Figure 39

REFERENCE Firebox Accessories / Parts

Cat. No.	Model No.	Description
88L53	FGE	Bag of Glowing Embers
80L42	FDVS	Bag of Decorative Volcanic Stone
H6319	----	Bag of Vermiculite



Glowing Embers

Figure 40

⚠ WARNING

- **DO NOT attempt to install the logs until the appliance installation has been completed, the gas line connected and tested for leaks and the initial burner operation has been checked out.**
- **The size and position of the log set was engineered to give the appliance a safe, reliable and attractive flame pattern. Any attempt to use a different log set in the fireplace will void the warranty and will result in incomplete combustion, sooting, and poor flame quality.**
- **Logs get very hot and will remain hot up to one hour after gas supply is turned off. Handle only when logs are cool. Turn off all electricity to the appliance before you install grate, volcanic stone, vermiculite, embers and logs.**
- **This appliance is not designed to burn wood. Any attempt to do so could cause irreparable damage to the appliance and prove hazardous to your safety.**
- **If logs are not installed according to the log installation instructions, flame impingement and improper combustion could occur and result in soot and/or excessive production of carbon monoxide (CO), a colorless, odorless, toxic gas.**

LOG PLACEMENT

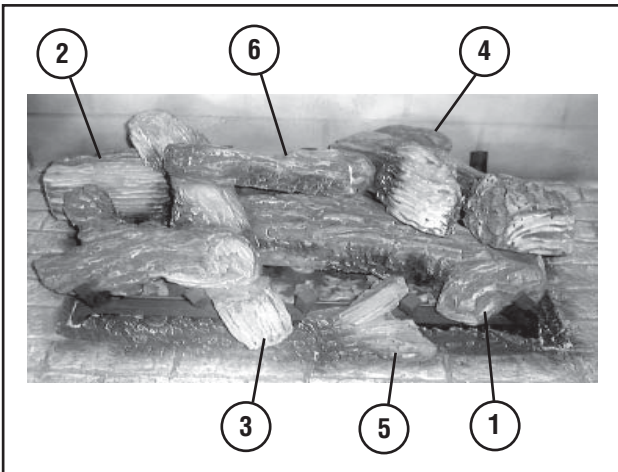

Log Number	Description
1	Log, Corner
2	Log, Rear/Left
3	Log, Front/Left
4	Log, Rear/Right
5	Log, Front/Center
6	Log, Center/Top

Catalog Number for the entire log set: 55M04

STEP 1

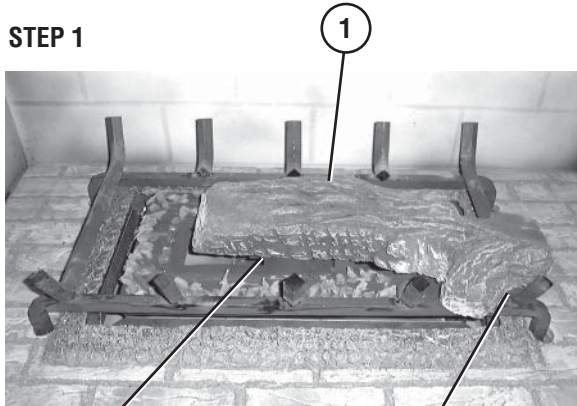

Position Groove At The Bottom Of Log (1) Over The Burner Log Support Bracket

Position The Groove At The Bottom Of Log (1) Over The Grate And Slide It Forward Against The Grate Here

STEP 2

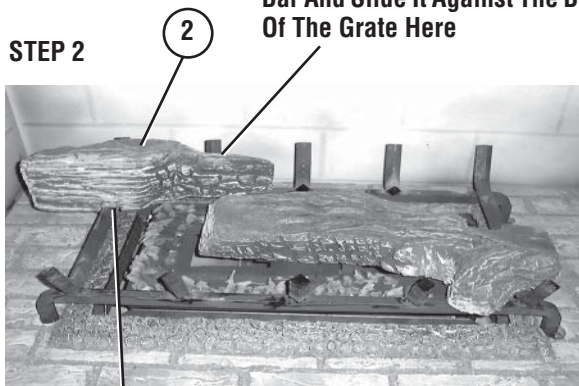

Position Groove At The Bottom Of Log (2) Over The Grate Here And Slide It Against The Back Of The Grate

Position Log (2) Over The Grate Bar And Slide It Against The Back Of The Grate Here

STEP 3

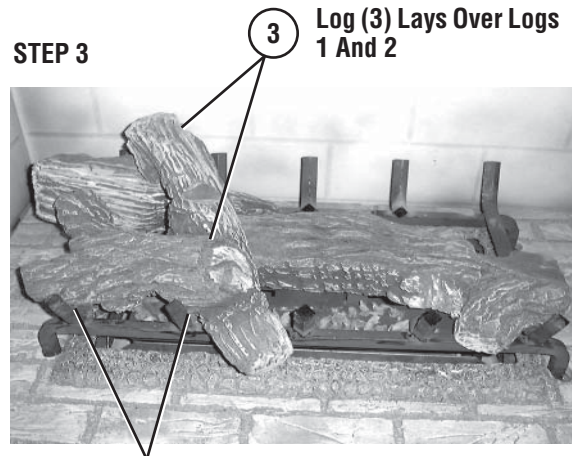

Place Bottom Hole Of Log (3) On Pin In Log (2). Position Grooves At The Bottom Of Log (3) Over The Grate.

Log (3) Lays Over Logs 1 And 2

STEP 4

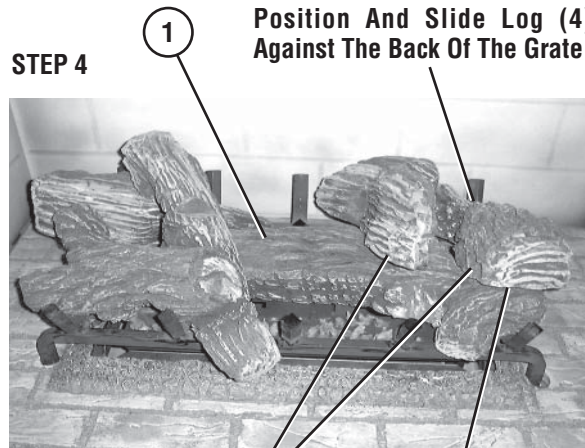

Place Log (4) Over The Flat Spot On Log (1) Here

Position And Slide Log (4) Against The Back Of The Grate

Figure 41

LOG PLACEMENT (CONTINUED)

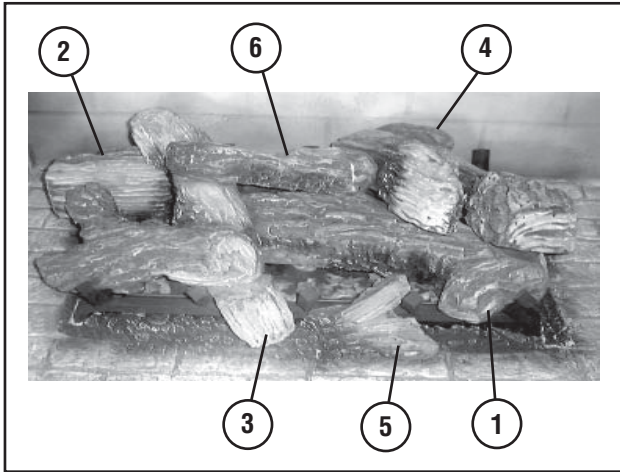

Log Number	Description
1	Log, Corner
2	Log, Rear/Left
3	Log, Front/Left
4	Log, Rear/Right
5	Log, Front/Center
6	Log, Center/Top

Catalog Number for the entire log set: 55M04

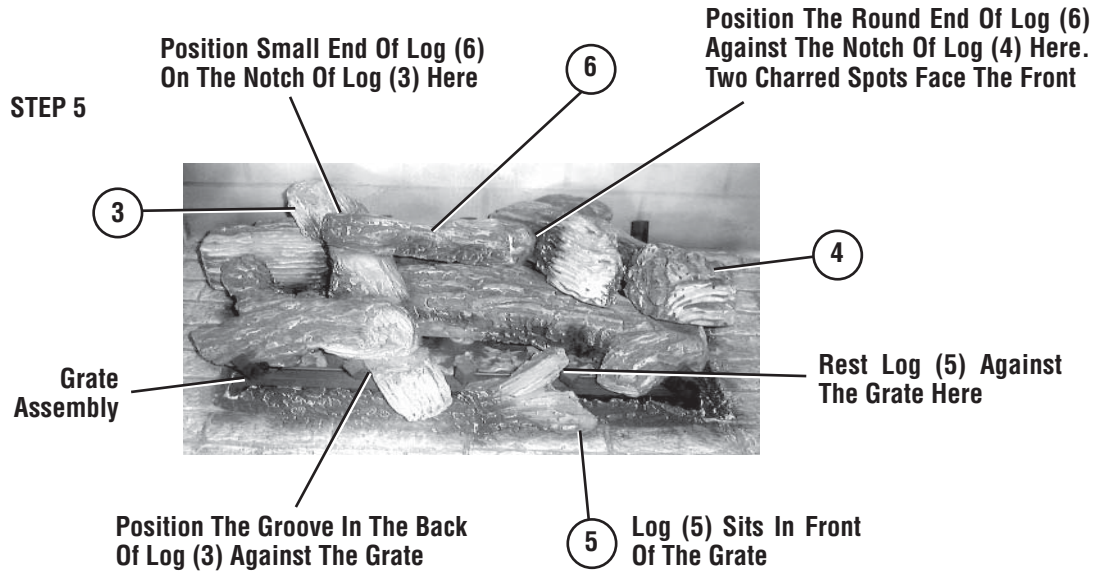

Figure 42

**BURNER ADJUSTMENTS
 (QUALIFIED TECHNICIANS ONLY)**

Flame Appearance and Sooting

Proper flame appearance is a flame which is blue at the base and becomes yellowish-orange in the body of the flame.

When the appliance is first lit, the entire flame may be blue and will gradually turn yellowish-orange during the first 15 minutes of operation. If the flame remains blue, or if the flame is orange with evidence of sooting (black tip), the air shutter opening may need to be adjusted.

If the air shutter opening is closed too far, sooting may develop. Sooting is indicated by black puffs developing at the tips of very long orange flames. Sooting results in black deposits forming on the logs, appliance inside surfaces and on exterior surfaces adjacent to the vent termination.

Sooting is caused by incomplete combustion in the flames and lack of combustion air entering the air shutter opening. To achieve a warm yellowish-orange flame with an orange body that does not soot, the shutter opening must be adjusted between these two extremes.

Air Shutter Adjustment Guidelines

- If there is smoke or soot present, first check the log set positioning to ensure that the flames are not impinging on any of the logs. If the log set is properly positioned and a sooting condition still exists, then the air shutter opening should be increased.
- The more offsets in the vent system, the larger the air shutter opening will need to be.
- An appliance operated with the air shutter opened too far, may have flames that appear blue and transparent. These weak, blue and transparent flames are termed anemic.
- Propane models may exhibit flames which candle or appear stringy. If this is present and persists, adjust the air shutter to a more closed position, then operate the appliance for a few more minutes to ensure that the flame normalizes and the flames do not appear sooty.

The following chart is provided to aid you in achieving the correct air shutter adjustment for your installation.

Air Shutter Adjustment Guidelines:		
Amount of Primary Air	Flame Color	Air Shutter Adjustment
If air shutter is closed too far →	Flame will be orange →	Air shutter gap should be increased
If air shutter is open too far →	Flame will be blue →	Air shutter gap should be decreased



Glowing Embers (Rockwool)

Figure 43 - Burner Flame Appearance

Burner Flame Adjustments

WARNING

- Air shutter adjustment should only be performed by a qualified professional service technician.
- Ensure glass enclosure panels are in place and sealed during adjustment.

CAUTION

- Soot will be produced if the air shutter is closed too much. Any damage due to sooting, resulting from improperly setting the air shutter, is not covered under the warranty.
- The air shutter door and nearby appliance surfaces are hot. Exercise caution to avoid injury while adjusting flame appearance.

1. Refer to **Figure 43** for proper flame appearance. To adjust the flame, rotate the adjustment rod toward the back or toward the front of the fireplace (rod located in the lower control area). Position the air shutter to the factory setting as shown in the table in **Figure 44**.
2. Light appliance (follow lighting procedure on lighting label in control compartment or see lighting instructions on **Pages 45 and 46**).
3. Allow the burner to operate for at least 15 minutes while observing the flame continuously to ensure that the proper flame appearance has been achieved. If the following conditions are present, adjust accordingly.
 - If flame appears weak or sooty, adjust the air shutter, incrementally, to a more open position until the proper flame appearance is achieved.
 - If flame remains blue, adjust the air shutter, incrementally, to a more closed position until the proper flame appearance is achieved.
4. Leave the control knob (off/pilot/on) in the ON position (millivolt appliances) and the burner OFF/ON switch OFF (and remote switches, if applicable).
5. When satisfied that the burner flame appearance is normal, re-install the lower control compartment door.

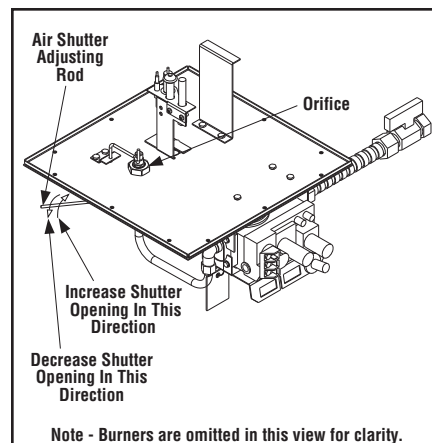

Note - Burners are omitted in this view for clarity.

MAIN BURNER FACTORY SHUTTER SETTING		
Model	Natural Gas inches (mm)	Propane Gas* inches (mm)
Marin40ST	1/16 (1.5)	7/16 (11)
* If field converted		

Adjustment Rod Positions (when viewed from above)

Figure 44

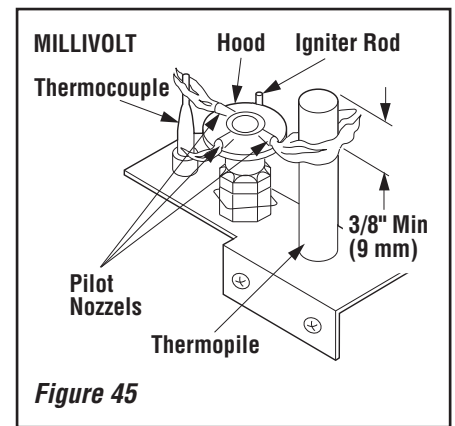

Figure 45

Millivolt Appliance Checkout

The pilot flame should be steady, not lifting or floating. Flame should be blue in color with traces of orange at the outer edge.

The top 3/8" (10 mm) at the pilot generator (thermopile) and the top 1/8" minimum (tip) of the quick drop out thermocouple should be engulfed in the pilot flame.

The flame should project 1" (25 mm) beyond the hood at all three ports (see **Figure 45**). Replace logs if removed for pilot inspection.

To light the burner; turn "ON" the control switch and rotate the gas valve control knob counterclockwise to the "ON" position ("ON" will be at the top side of the valve).

WIRING DIAGRAM

A wiring diagram is provided here for reference purposes only. This information is also provided on schematics attached directly to the appliance on a pullout panel located within the control compartment.

CAUTION: LABEL ALL WIRES PRIOR TO DISCONNECTION WHEN SERVICING CONTROLS. WIRING ERRORS CAN CAUSE IMPROPER AND DANGEROUS APPLIANCE OPERATION.

ATTENTION: AU MOMENT DE L'ENTRETIEN DES COMMANDES, ÉTIQUETEZ TOUS LES FILS AVANT DE LES DÉBRANCHER. DES ERREURS DE CÂBLAGE PEU-VENT ENTRAÎNER UN FONCTIONNEMENT INADÉQUAT ET DANGEREUX.

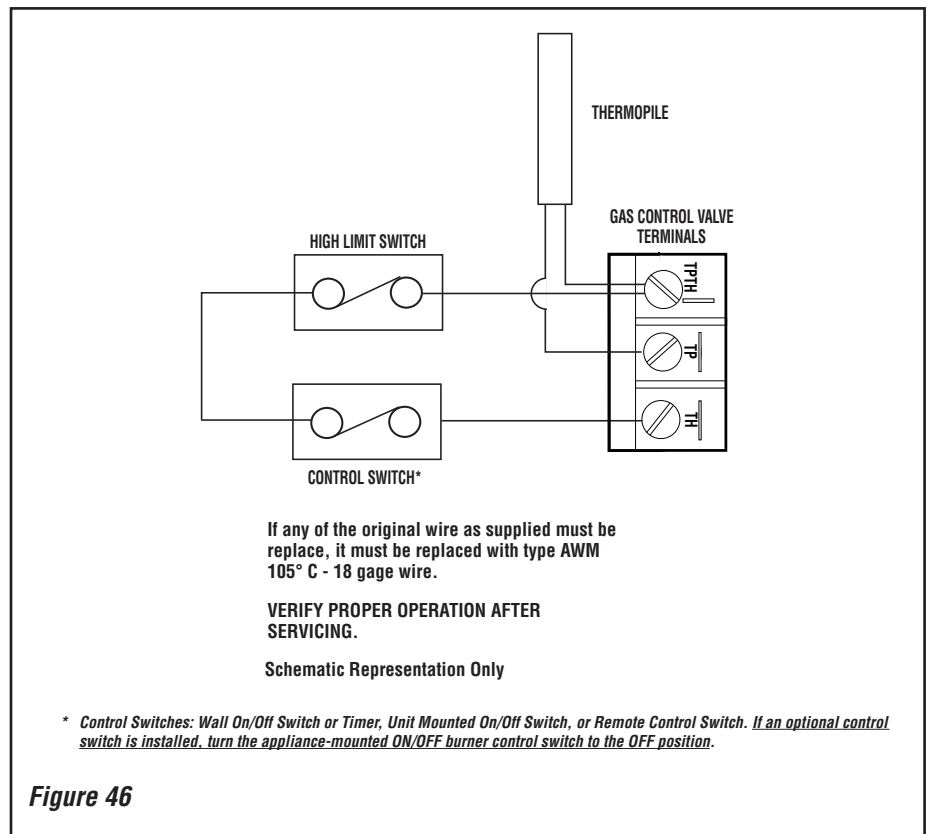

REPLACEMENT PARTS

A complete parts list is found at the end of this manual. Use only parts supplied from the manufacturer.

With proper care and maintenance, your appliance will provide many years of enjoyment. If you should experience any problem, first refer to the troubleshooting guide in this manual. If problem persists, contact your Innovative Hearth Products dealer or distributor.

Normally, all parts should be ordered through your Innovative Hearth Products distributor or dealer.

Parts will be shipped at prevailing prices at time of order.

When ordering repair parts, always give the following information:

1. The model number of the appliance.
2. The serial number of the appliance.
3. The part number.
4. The description of the part.
5. The quantity required.
6. The installation date of the appliance.

If you encounter any problems or have any questions concerning the installation or application of this system, please contact your dealer or distributor.

INNOVATIVE HEARTH PRODUCTS
 1508 Elm Hill Pike, Suite 108
 Nashville, TN 37210
 visit us at Astria.us.com

PRODUCT REFERENCE INFORMATION

We recommend that you record the following important information about your fireplace. Please call Innovative Hearth Products for the phone number of your nearest Innovative Hearth Products dealer who will answer your questions or address your concerns.

Your Fireplace's Model Number _____

Your Fireplace's Serial Number _____

The Date On Which Your Fireplace Was Installed _____

The Type of Gas Your Fireplace Uses _____

Your Dealer's Name _____

ACCESSORY COMPONENTS

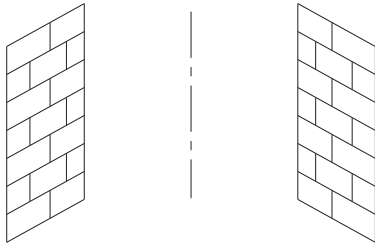

Firebox Liner Kit

The brickaded firebox liner kit include ceramic panels as shown here. The panels have brick-like features in relief.

Brickaded Firebox Liner Kit		
Cat. No.	Model No.	Description
H0779	EBLK-ST	Brickaded Firebox Liner Kits



Touch-Up Paint Kits

Repair of minor scratches and discoloration of the appliance black painted surfaces may be accomplished with the touch-up paint kit.

Touch-Up Paint Kits		
Cat. No.	Model No.	Description
F1881	SCTPSAB	Black touch-up paint, firebox interior
F1882	SCITPSAB	Black touch-up paint, powder coat exterior

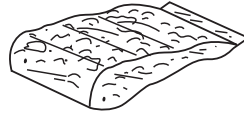

- Bag of Glowing Embers**
- Bag of Volcanic Stone**
- Bag of Vermiculite**

Replacement ember materials, volcanic stone or vermiculite are available for use with these appliances. Order kits as part of the periodic maintenance of the appliance.

Decorative Firebox Accessories		
Cat. No.	Model No.	Description
88L53	FGE	Bag of Glowing Embers
80L42	FDVS	Bag of Decorative Volcanic Stone
H6319	----	Bag of Vermiculite

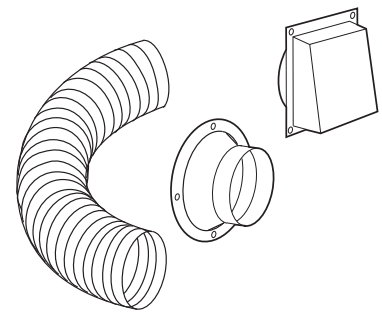

Outside Air Kits Models FOAK-4 and FOAK-4LD

Outside Air kits are available with duct (FOAK-4) and without duct (FOAK-4LD) for use if outside combustion air is required or desired. If model FOAK-4LD is used it must be used in conjunction with locally purchased, non-combustible Class 1 or Class 0 flexible duct.

Outside Combustion Air Kits		
Cat. No.	Model No.	Description
81L87	FOAK-4	(with duct)
81L88	FOAK-4LD	(without duct)

ACCESSORY COMPONENTS CONTINUED



Manual or up to 3 hr Countdown Timer modes

- LCD display
- Displays room temp. in °F or °C
- Flame icon and low battery indicator
- Includes batteries
- Wall clip included
- Receiver may be wall mounted or placed in the control compartment
- Includes white face plate
- Flame icon
- Low battery indicator
- Batteries included

Remote, Two Button, Timer, On/Off Or Timer Mode		
Cat. No.	Model No.	Description
H8860	RC-S-1	Remote Control



Cost Effective Solution

- Simple On/Off operation

Kit includes:
 Remote and Receiver

RCKit4001, Simple On/Off		
Cat. No.	Model No.	Description
F2236	RCKit4001	Remote Control

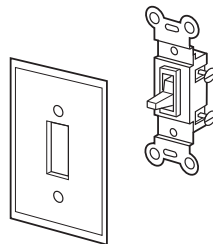

OFF/ON Wall Switch Kit

The OFF/ON wall switch kit may be used to control the operation of the fireplace burner. Install the OFF/ON wall switch in a convenient location near the fireplace.

White Wall Switch Kit		
Cat. No.	Model No.	Description
85L87	FWSK	OFF/ON Wall Switch Kit



Wall Control

- 4-button timer with 30/60/120/OFF minutes
- Wall surface mounted
- Connects to wall switch wire
- Perfect for rental and resort applications

Wall Switch, Countdown Timer		
Cat. No.	Model No.	Description
H8863	WS-S-TMR	Wall Switch

MAINTENANCE SCHEDULE

Annually (Before the onset of the Burning Season)

MAINTENANCE TASK	ACCOMPLISHING PERSON	PROCEDURE
Inspecting/Cleaning Burner, Logs and Controls	Qualified Service Technician	Inspect valve and ensure it is properly operating. Check piping for leaks. Vacuum the control compartment, fireplace logs and burner area.
Check Flame Patterns and Flame Height	Qualified Service Technician	Refer to Figure 25 on Page 22 and verify the flame pattern and height displayed by the appliance conforms to the picture. Flames must not impinge on the logs. Ensure flames are steady (not lifting or floating).
Inspecting/Cleaning Pilot and Burner	Qualified Service Technician	Refer to Figure 45 on Page 40 . Remove any surface build-up on pilot and burner assembly. Wipe the pilot nozzles, igniter/ flame rod and hood. Ensure the pilot flame engulfs the flame sensor as shown.
Checking Vent System	Qualified Service Technician	Inspect the vent system at the top and at the base (within the firebox) for signs of blockage or obstruction. Look for any signs of dislocation or deterioration of the vent components. NOTE: Excessive condensation can cause corrosion of caps, pipe & fittings (excessive condensation can be caused by long lateral runs, too many elbows and/or exterior portions of the system being exposed to cold weather). Also inspect wall straps or plumbers's tape to ensure it is secure and in place.
Appliance Checkout	Qualified Service Technician	Perform the appropriate appliance checkout procedure detailed in this manual.
Replacing Glowing Ember (rockwool) Materials	Homeowner/Qualified Service Technician	Remove old ember materials (rockwool) and vacuum the ember placement area. Place new embers as described in this document.

Periodically (After the Burning Season)

MAINTENANCE TASK	ACCOMPLISHING PERSON	PROCEDURE
Cleaning Firebox Interior	Homeowner	Carefully remove logs, glowing embers (rockwool), volcanic stone and vermiculite. Vacuum out interior of the firebox. Clean firebox walls and log grate. Replace logs, glowing embers and vermiculite as detailed in this manual.
Check Flame Patterns and Flame Height	Homeowner	Refer to Figure 25 on Page 22 and verify the flame pattern and height displayed by the appliance conforms to the picture. Flames must not impinge on the logs.
Checking Vent System	Homeowner	Inspect the vent system at the top and at the base (within the firebox) for signs of blockage or obstruction. Look for any signs of dislocation of the vent components.
Cleaning Front Glass Enclosure Panel	Homeowner	Clean as necessary following the directions provided in this manual. DO NOT TOUCH OR ATTEMPT TO CLEAN GLASS WHILE HOT.

LIGHTING INSTRUCTIONS – MILLIVOLT GAS VALVE



FOR YOUR SAFETY READ BEFORE LIGHTING

WARNING: If you do not follow these instructions exactly, a fire or explosion may result causing property damage, personal injury or loss of life.



- A. This appliance has a pilot which must be lighted by a piezo igniter. When lighting the pilot, follow these instructions exactly.
- B. **BEFORE LIGHTING** smell all around the appliance area for gas. Be sure to smell next to the floor because some gas is heavier than air and will settle on the floor.

WHAT TO DO IF YOU SMELL GAS:

- Do not try to light any appliance.
- Do not touch any electric switch; do not use any phone in your building.

- Immediately call your gas supplier from a neighbor's phone. Follow the gas supplier's instructions.
 - If you cannot reach your gas supplier, call the fire department.
- C. Use only your hand to push in or turn the gas control knob. Never use tools. If the knob will not push in or turn by hand, don't try to repair it, call a qualified service technician. Force or attempted repair may result in a fire or explosion.
- D. Do not use this appliance if any part has been under water. Immediately call a qualified service technician to inspect the appliance and to replace any part of the control system and any gas control which has been under water.

LIGHTING INSTRUCTIONS

1. **STOP!** Read the safety information above on this label.
2. (If applicable) Set the thermostat to lowest setting. Turn wall on/off switch, unit mounted on/off switch or remote control switch "OFF."
3. Turn OFF all electric power to the appliance.
4. Access the control compartment.
5. Push in gas control knob slightly and turn clockwise  to "OFF."
NOTE: Knob cannot be turned from "PILOT" to "OFF" unless knob is pushed in slightly. Do Not force.
6. Wait five (5) minutes to clear out any gas. Then smell for gas, including near the floor. If you smell gas, **STOP!** Follow "B" in the safety information above on this label. If you don't smell gas, go to the next step.
7. Find pilot - located in firebox on the same plane as the top of the burner.
8. Turn knob on gas control counterclockwise  to "PILOT."
9. Push in control knob all the way and hold in. Immediately light the pilot by triggering the piezo igniter (pushing the button) until pilot lights. Continue to hold the control knob in for about 1-1/2 minutes after the pilot is lit. Release knob and it will pop back up. Pilot should remain lit. If it goes out, repeat steps 5 through 9.
 - If knob does not pop up when released, stop and immediately call your service technician or gas supplier.

- If the pilot will not stay lit after several tries, turn the gas control knob to "OFF" and call your service technician or gas supplier.
10. Turn gas control knob counterclockwise  to "ON."
 11. Close control compartment.
 12. (If applicable) Turn on all electrical power to the appliance.
 13. (If applicable) Set thermostat to desired setting. Turn wall on/off switch, unit mounted on/off switch or remote control switch "ON."

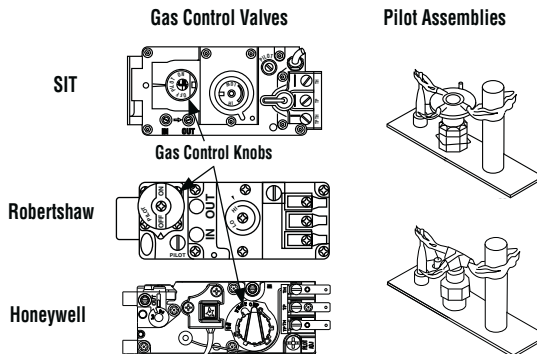

TO TURN OFF GAS TO APPLIANCE

1. (If applicable) Set the thermostat to lowest setting. Turn wall on/off switch, unit mounted on/off switch or remote control switch "OFF."
2. Turn OFF all electric power to the appliance, if service is to be performed.
3. Access the control compartment.
4. Push in gas control knob slightly and turn clockwise  to "OFF." Do not force.
5. Close the main line gas shut-off valve.
6. Close control compartment.



DANGER



**HOT GLASS WILL
CAUSE BURNS.
DO NOT TOUCH GLASS
UNTIL COOLED.
NEVER ALLOW CHILDREN
TO TOUCH GLASS.**

A barrier designed to reduce the risk of burns from the hot viewing glass is provided with this appliance and shall be installed for the protection of children and other at-risk individuals.

INSTRUCTIONS D'ALLUMAGE – VANNE GAZ MILLIVOLT



POUR PLUS DE SÉCURITÉ, LIRE AVANT D'ALLUMER

AVERTISSEMENT. Quiconque ne respecte pas à la lettre les instructions dans la présente notice risque de déclencher un incendie ou une explosion entraînant des dommages, des blessures ou la mort.

A. Cet appareil est muni d'une veilleuse qui doit être allumée avec un allumeur piézo-électrique. Respectez les instructions ci-dessous à la lettre.

B. **AVANT L'ALLUMAGE:** Avant d'allumer la veilleuse, reniflez tout autour de l'appareil pour déceler une odeur de gaz. Reniflez près du plancher, car certains gaz sont plus lourds que l'air et peuvent s'accumuler au niveau du sol.

QUE FAIRE SI VOUS SENTEZ UNE ODEUR DE GAZ :

- Ne pas tenter d'allumer d'appareil.
- Ne touchez à aucun interrupteur ; ne pas vous servir des téléphones se trouvant dans le bâtiment.
- Appelez immédiatement votre fournisseur de gaz depuis un voisin. Suivez

les instructions du fournisseur.

- Si vous ne pouvez rejoindre le fournisseur, appelez le service des incendies.
- C. Ne pousser ou tourner la manette d'admission du gaz qu'à la main. Ne jamais employer d'outil à cette fin. Si la manette reste coincée, ne tentez pas de la réparer; appelez un technicien qualifié. Quiconque tente de forcer la manette ou de la réparer peut provoquer une explosion ou un incendie.
- D. N'utilisez pas cet appareil s'il a été plongé dans l'eau, même partiellement. Faites inspecter l'appareil par un technicien qualifié et remplacez toute partie du système de contrôle et toute commande qui ont été plongés dans l'eau.

INSTRUCTIONS D'ALLUMAGE

1. **ARRÊTEZ !** Lisez les instructions de sécurité sur la portion supérieure de cette étiquette.
2. (Si applicable) Réglez le thermostat à la température la plus basse. Tournez l'interrupteur murale, l'interrupteur sur l'unité ou le contrôle à distance à "OFF."
3. Coupez l'alimentation électrique de l'appareil.
4. Accédez au compartiment de contrôle.
5. Enfoncez légèrement le bouton de réglage du gaz et tournez-le dans le sens des aiguilles d'une montre jusqu'à la position d'arrêt "OFF".
Remarque: Il est impossible de tourner le bouton de "PILOT" à "OFF" à moins qu'il ne soit légèrement enfoncé. Ne le forcez pas.
6. Attendre cinq (5) minutes pour laisser échapper tout le gaz. Reniflez tout autour de l'appareil, y compris près du plancher, pour déceler une odeur de gaz. Si vous sentez une odeur de gaz, **ARRÊTEZ !** Passez à l'étape B des instructions de sécurité sur la portion supérieure de cette étiquette. S'il n'y a pas d'odeur de gaz, passez à l'étape suivante.
7. Trouver le pilote – Situé dans l'âtre sur la même surface que le dessus du brûleur.
8. Tournez le bouton de contrôle sur la valve à gaz dans le sens antihoraire vers "Pilote".
9. Enfoncez le bouton de réglage jusqu'au fond et gardez-le enfoncé. Allumez immédiatement la veilleuse en déclenchant l'allume-gaz à étincelle (en poussant le bouton) jusqu'à ce que la veilleuse s'enflamme. Continuez de tenir le bouton de réglage enfoncé pendant environ 90 secondes après l'allumage de la veilleuse. Relâchez le bouton et il sortira subitement. La veilleuse devrait rester allumée. Si elle s'éteint, répétez les étapes 5 à 8 inclusivement.

- Si la manette ne se soulève pas d'elle-même lorsqu'on la relâche, arrêter et appeler immédiatement un technicien qualifié ou le fournisseur de gaz.
- Si la veilleuse ne reste pas allumée après plusieurs tentatives, réglez la manette d'admission du gaz à la position OFF et appelez un technicien qualifié ou le fournisseur de gaz.

10. Tournez le bouton de réglage du gaz en sens inverse des aiguilles d'une montre jusqu'à sa position de marche "ON".
11. Fermer le compartiment de contrôle.
12. (Si applicable) Mettez l'appareil sous tension.
13. (Si applicable) Réglez le thermostat à la température désirée. Tournez l'interrupteur murale, l'interrupteur sur l'unité ou le contrôle à distance à "ON."

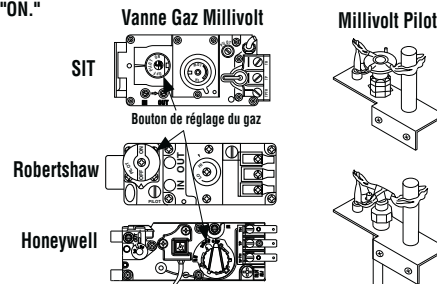

COMMENT COUPER L'ADMISSION DE GAZ DE L'APPAREIL

1. (Si applicable) Réglez le thermostat à la température la plus basse. Tournez l'interrupteur murale, l'interrupteur sur l'unité ou le contrôle à distance à "OFF."
2. Coupez l'alimentation électrique de l'appareil s'il faut procéder à l'entretien.
3. Accédez au compartiment de contrôle.
4. Enfoncez légèrement le bouton de réglage du gaz et tournez-le dans le sens des aiguilles d'une montre jusqu'à la position d'arrêt "OFF". Ne forcez pas le bouton.
5. Fermer la valve de gaz principale.
6. Fermer le compartiment de contrôle.



DANGER



VITRE CHAUDE
RISQUE DE BRÛLURES.
NE TOUCHEZ PAS UNE VITRE
NON REFROIDIE.
NE LAISSEZ JAMAIS UN ENFANT
DE TOUCHER LA VITRE.

L'écran pare-étincelles fourni avec ce foyer réduit le risque de brûlure en cas de contact accidentel avec la vitre chaude et doit être installé pour la protection Des enfants et Des personnes à risques.

TROUBLESHOOTING

NOTE: Before troubleshooting the gas control system, Ensure external gas shut off valve, located at gas supply inlet, (and wall switch, if applicable), is in the "ON" position.

Important: Valve system troubleshooting should only be accomplished by a qualified service technician.

TROUBLESHOOTING GUIDE - MILLIVOLT GAS CONTROL SYSTEM

SYMPTOM	POSSIBLE CAUSES	CORRECTIVE ACTION
<p>1. Spark igniter will not light pilot after repeated triggering of igniter button.</p> <p>WARNING: if the pilot will not light after 1 minute of attempting, wait for at least 5 minutes for gas to clear before attempting again.</p>	<p>A. Defective igniter (no spark at electrode).</p>	<p>Check for spark at electrode and pilot; if no spark and electrode wire is properly connected, replace igniter.</p>
	<p>B. Defective or misaligned electrode at pilot (spark at electrode).</p>	<p>Using a match, light pilot. If pilot lights, turn off pilot and trigger the igniter button again. If pilot lights, an improper gas mixture caused the bad lighting and a longer purge period is recommended. If pilot will not light – check gap at electrode and pilot – should be 1/8" to have a strong spark. If gap measures 1/8", replace pilot (see Figure 45 on Page 40).</p>
	<p>C. Gas supply pressure errant.</p>	<p>Check inlet gas pressure. It should be within the limits as marked on the rating plate.</p>
	<p>D. Pilot orifice plugged.</p>	<p>Clean or replace pilot orifice.</p>
<p>2. Pilot will not stay lit after carefully following the lighting instructions.</p>	<p>A. Defective pilot generator (thermocouple).</p>	<p>Check pilot flame, it must impinge on thermocouple (see Figure 45 on Page 40). Clean and/or adjust pilot for maximum flame impingement on thermocouple. Ensure that the connection between the valve and thermocouple are tight and secure.</p>
<p>3. Pilot burning, no gas to burner, Valve knob "ON," and the (standard) burner OFF/ON switch is "ON." Read important note below.</p> <p>IMPORTANT NOTE: If an optional *remote switch is used for burner operation, if the standard burner OFF/ON switch is still installed on appliance it must be in the "OFF" position.</p> <p>* Optional remote switch kits - wall switch or timer, or remote control.</p>	<p>A. Wall switch or wires defective.</p>	<p>Check wall switch and wires for proper connections. Jumper wire across terminals at wall switch, if burner comes on, replace defective wall switch. If okay, jumper wires across wall switch wires at valve, if burner comes on, wires are faulty or connections are bad.</p>
	<p>B. Thermopile may not be generating sufficient millivolts.</p>	<p>Check thermopile with millivolt meter. Take reading at thermopile terminals of gas valve. Should read 325 millivolts minimum with optional wall switch "OFF." Replace faulty thermopile if reading is below specified minimum.</p>
	<p>C. Plugged burner orifice.</p>	<p>Check burner orifice for blockage and remove.</p>
	<p>D. OFF/ON Switch & *Remote Switch are in the "ON" position resulting in excessive resistance.</p>	<p>When turning on the burner using a *remote switch, ensure that the standard OFF/ON switch is in the "OFF" position. If both switches are in the ON position, it may result in excessive resistance (& millivolt drainage) and the burner may not come on.</p>
<p>4. Frequent pilot/burner outage problem.</p>	<p>A. Pilot flame may be too low or blowing (high) causing the pilot/valve safety to drop out.</p>	<p>Clean and/or adjust pilot flame for maximum flame impingement on thermocouple (see Figure 45 on Page 40).</p>

REPLACEMENT PARTS LIST

No.	Description	Natural and Propane	
		Part No.	Qty.
1	Hood, Black - 40"	J7536	2
2	Glass Enclosure Assembly - 40"	H6365	2
3	Log Set	55M04	1
4	Bag of Vermiculite	H6319	1
5	Bag of Embers (rockwool)	88L53	1
6	Bag of Decorative Volcanic Stone	80L42	1
7	Burner Assembly	H6267	1
---	Gasket, Venturi Tube Mounting	43K85	1
9	Latch, Glass Enclosure Panel	69L21	2
10	Switch, Rocker	27K30	1
11	Limit Switch	62L16	1
12	Flex Gas Line Connector	93L32	1
13	Barrier	J7420	2
14	Front Face Assembly with Barrier	J7530	2
---	Astria Badge (logo)	J7593	1

Gas Controls — SIT Millivolt					
No.	Description	Natural		Propane	
		Part No.	Qty.	Part No.	Qty.
15	Gas Valve - SIT	H6209	1	88J53	1
16	Piezo Igniter	10K86	1	10K86	1
17	Pilot Assembly	69L17	1	69L18	1
18	Pilot Generator (thermopile)	60J79	1	60J79	1
19	Thermocouple	74L57	1	74L57	1
20	Pilot Tube	74L56	1	74L56	1
21	Electrode and Cable	H6212	1	H6212	1
22	Modesty Panel / Sticker Assembly	H6305	1	H6305	1
23	Grate Assembly	H6287	1	H6287	1

Gas Orifices, Main — SIT					
No.	Description	Natural		Propane	
		Part No.	Qty.	Part No.	Qty.
24	Burner Orifice, Natural Gas	37L82	1	74L88	1

Contact a Innovative Hearth Products dealer to obtain any of these parts.

WARNING

Failure to position the parts in accordance with these diagrams or failure to use only parts specifically approved with this appliance may result in property damage or personal injury.

AVERTISSEMENT

Risque de dommages ou de blessures si les pièces ne sont pas installées conformément à ces schémas et ou si des pièces autres que celles spécifiquement approuvées avec cet appareil sont utilisées.

WARNING

Never use substitute materials. Use of non-approved parts can result in poor performance and safety hazards.

REPLACEMENT PARTS

Cat. No.	Model
F0869	Marin 40STMN

**NOTE: See the tables on Page 48
 for replacement parts applicables.**

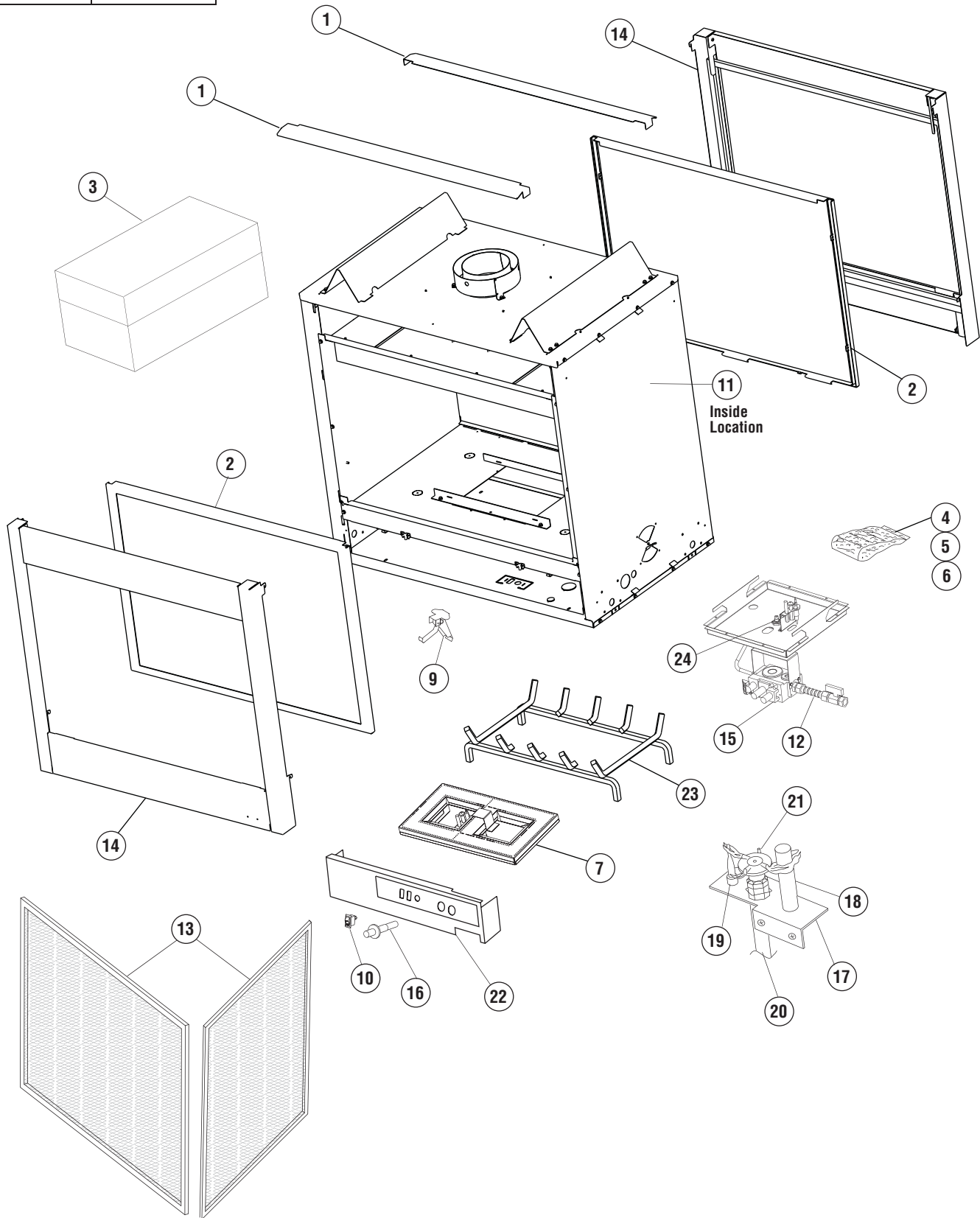

Innovative Hearth Products Astria® Brand Gas Fireplace Limited Lifetime Warranty

THE WARRANTY

Innovative Hearth Products ("IHP") Limited Lifetime Warranty warrants your Astria® brand gas fireplace ("Product") to be free from defects in materials and workmanship at the time of manufacture. The product body, firebox and barrier carry the Limited Lifetime Warranty. Ceramic glass carries the Limited Lifetime Warranty against thermal breakage only. After installation, if covered components manufactured by IHP are found to be defective in materials or workmanship during the Limited Lifetime Warranty period and while the Product remains at the site of the original installation, IHP will, at its option, repair or replace the covered components. If repair or replacement is not commercially practical, IHP will, at its option, refund the purchase price or wholesale price of the IHP product, whichever is applicable. IHP will also pay IHP prevailing labor rates, as determined in its sole discretion, incurred in repairing or replacing such components for up to five years. THERE ARE EXCLUSIONS AND LIMITATIONS to this Limited Lifetime Warranty as described herein.

COVERAGE COMMENCEMENT DATE

Warranty coverage begins on the date of purchase. In the case of new home construction, warranty coverage begins on the date of first occupancy of the dwelling or six months after the sale of the Product by an independent IHP dealer/distributor, whichever occurs earlier. The warranty shall commence no later than 24 months following the date of product shipment from IHP, regardless of the installation or occupancy date.

EXCLUSIONS AND LIMITATIONS

This Limited Lifetime Warranty applies only if the Product is installed in the United States or Canada and only if operated and maintained in accordance with the printed instructions accompanying the Product and in compliance with all applicable installation and building codes and good trade practices.

This warranty is non-transferable and extends to the original owner only. The Product must be purchased through a listed supplier of IHP and proof of purchase must be provided. The product body, firebox and barrier carry the Limited Lifetime Warranty from the date of installation. Vent components, trim components and paint are excluded from this Limited Lifetime Warranty. The following do not carry the Limited Lifetime Warranty but are warranted as follows:

- Burner** – Repair or replacement for five years from the date of installation
- Gas components & electrical components** – Repair or replacement for one year from the date of installation
- Gaskets** – Repair or replacement for one year from the date of installation
- Gold & nickel plating** – Replacement for two years from date of installation. Excludes tarnishing
- Labor coverage** – Prevailing IHP labor rates apply for the warranty period of the component
- Light bulbs & batteries** – Replacement for 90 days from the date of installation
- Logs** – Replacement for five years from the date of installation against thermal breakage only
- Optional blowers & remote controls** – Repair or replacement for one year from the date of installation
- Optional glass doors & optional glass accessories** – Repair or replacement for 90 days from the date of installation
- Optional surrounds** – Stone/Natural Materials: Replacement for one year against cracking or breakage due to thermal stress. Other Materials: Replacement for one year. Excludes surface and hairline cracks and scratches or slight color changes that do not affect the operation or safety of the unit
- Tempered Glass** -Replacement for one year from the date of installation

Parts not otherwise listed carry a 90 day warranty from the date of installation.

Whenever practicable, IHP will provide replacement parts, if available, for a period of 10 years from the last date of manufacture of the Product.

IHP will not be responsible for: (a) damages caused by normal wear and tear, accident, riot, fire, flood or acts of God; (b) damages caused by abuse, negligence, misuse, or unauthorized alteration or repair of the Product affecting its stability or performance (The Product must be subjected to normal use. The Product is designed to burn either natural or propane gas only. Burning conventional fuels such as wood, coal or any other solid fuel will cause damage to the Product, will produce excessive temperatures and could result in a fire hazard.); (c) damages caused by failing to provide proper maintenance and service in accordance with the instructions provided with the Product; (d) damages, repairs or inefficiency resulting from faulty installation or application of the Product.

IHP is not responsible for inadequate fireplace system draft caused by air conditioning and heating systems, mechanical ventilation systems, or general construction conditions which may generate negative pressure in the room in which the appliance is installed. Additionally IHP assumes no responsibility for drafting conditions caused by venting configurations, adjoining trees or buildings, adverse wind conditions or unusual environmental factors and conditions that affect the operation of the unit.

This Limited Lifetime Warranty covers only parts and labor as provided herein. In no case shall IHP be responsible for materials, components or construction, which are not manufactured or supplied by IHP or for the labor necessary to install, repair or remove such materials, components or construction. Additional utility bills incurred due to any malfunction or defect in equipment are not covered by this warranty. All replacement or repair components will be shipped F.O.B. from the nearest stocking IHP factory.

LIMITATION ON LIABILITY

It is expressly agreed and understood that IHP's sole obligation and the purchaser's exclusive remedy under this warranty, under any other warranty, expressed or implied, or in contract, tort or otherwise, shall be limited to replacement, repair, or refund, as specified herein.

In no event shall IHP be liable for any incidental or consequential damages caused by defects in the Product, whether such damage occurs or is discovered before or after repair or replacement, and whether such damage is caused by IHP's negligence. IHP has not made and does not make any representation or warranty of fitness for a particular use or purpose, and there is no implied condition of fitness for a particular use or purpose.

IHP makes no expressed warranties except as stated in this Limited Lifetime Warranty. The duration of any implied warranty is limited to the duration of this expressed warranty.

No one is authorized to change this Limited Lifetime Warranty or to create for IHP any other obligation or liability in connection with the Product. Some states and provinces do not allow the exclusion or limitation of incidental or consequential damages, so the above limitations or exclusions may not apply to you. The provisions of this Limited Lifetime Warranty are in addition to and not a modification of or subtraction from any statutory warranties and other rights and remedies provided by law.

INVESTIGATION OF CLAIMS AGAINST WARRANTY

IHP reserves the right to investigate any and all claims against this Limited Lifetime Warranty and to decide, in its sole discretion, upon the method of settlement.

To receive the benefits and advantages described in this Limited Lifetime Warranty, the appliance must be installed and repaired by a licensed contractor approved by IHP.

Contact IHP at the address provided herein to obtain a listing of approved dealers/distributors. **IHP shall in no event be responsible for any warranty work done by a contractor that is not approved without first obtaining IHP's prior written consent.**

HOW TO REGISTER A CLAIM AGAINST WARRANTY

In order for any claim under this warranty to be valid, you must contact the IHP dealer/distributor from which you purchased the product. If you cannot locate the dealer/distributor, then you must notify IHP in writing. IHP must be notified of the claimed defect in writing within 90 days of the date of failure. Notices should be directed to the IHP Warranty Department at 1508 Elm Hill Pike, Suite 108, Nashville, TN 37210 or visit our website at WWW.ASTRIA.US.COM.

Astria.US.com

Record the following important information about your fireplace:

Fireplace model number	
Fireplace serial number	
Date fireplace was Installed	
Type of gas fireplace uses	
Dealer name	

Innovative Hearth Products reserves the right to make changes at any time, without notice, in design, materials, specifications, prices and also to discontinue colors, styles and products. Consult your local distributor for fireplace code information.

