

# FIREMAGIC®

## BAR CADDY SLIDE-IN MODEL #1D-S0



Shown with cover in place and optional **trim kit (part #3807)**

**BEFORE INSTALLATION, CHECK THAT YOU HAVE ALL OF THE PARTS AS LISTED TO THE RIGHT.**

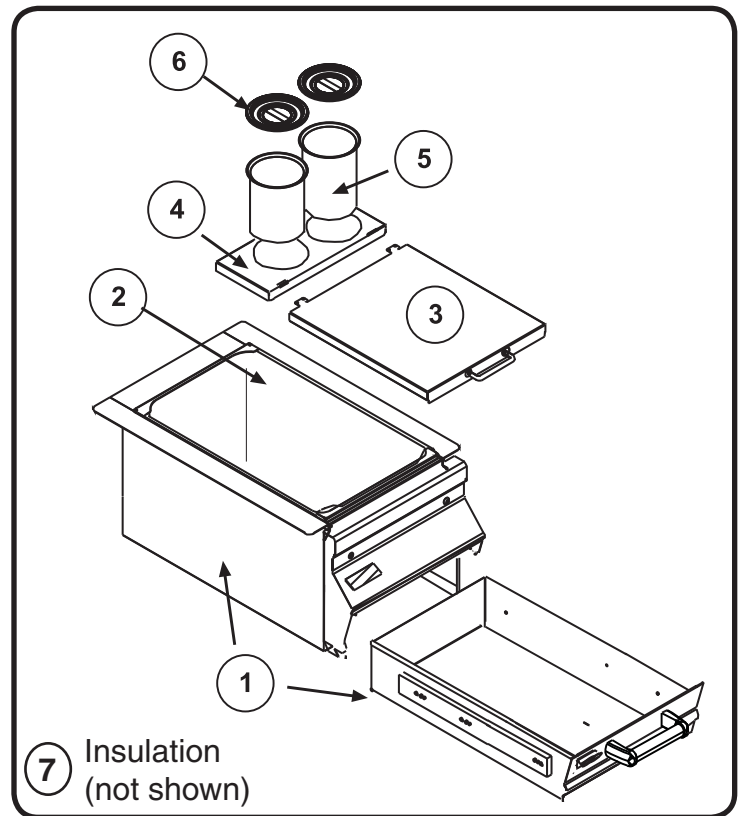

7. Insulation (not shown)

- 1. 400237 Bar caddy assembly (1)
- 2. 10127 Splash pan 21"x 13"x 6" (1)
- 3. 200331 Cover, bar caddy (1)
- 4. 200250 Top, bar caddy (1)
- 5. 10128 Condiment/bottle holder pan (2)
- 6. 10130 Cap, condiment/bottle holder pan (2)
- 7. Insulation (5)

### INSTALLATION INSTRUCTIONS

**NOTICE TO INSTALLER:** Please leave these instructions with the consumer.  
**NOTICE TO CONSUMER:** Please retain for future reference.

Before installation, ensure the opening dimensions are correct (Fig. 1). Then simply slide the bar caddy assembly into place in the cut-out area. Place the 5 pieces of insulation inside the caddy, on the bottom and against the sides. Place the splash pan inside the caddy, and put the caddy top and cover in place. Insert the holder pans and their pan lids. It is now ready for use.

**TO USE AS A FOOD WARMER, SEE REVERSE.**

#### **WARNING**

Improper installation, adjustment, alteration, service or maintenance can cause injury or property damage. Refer to this manual. For assistance or additional information consult a qualified, professional installer or service agency.

**INSTALLATION OPENING:  
Front to Back Depth 22-1/2"  
Width 14-1/4", Height 12"**

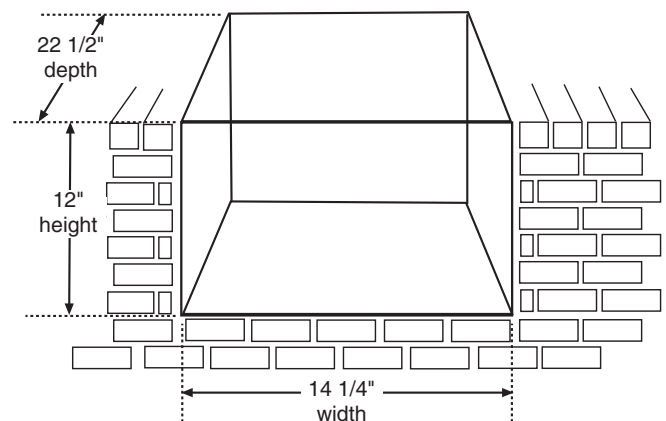

**Fig. 1.**  
**Cut out dimensions for bar caddy**

# OPTIONAL BAR CADDY HEATER ACCESSORY

Model # 3565



1. Support, can, bar caddy (1)
2. Chafing dish fuel (2)
3. Steamer pan, 1/2 size (2)
4. Lid steamer, 1/2 pan (2)

**BEFORE INSTALLATION CHECK THAT YOU HAVE ALL THE PARTS AS LISTED ABOVE.**

**Note:** Refer to the PARTS LIST above and on page 1 of this instruction manual to identify the items listed below.

**To install and operate, follow these simple steps:**

**Step 1.** Where installed, remove the bar caddy cover, the bar caddy top, condiment/bottle holder pans, their caps, and splash pan.

**Step 2.** Remove the insulation from inside the bar caddy.

**Step 3.** Fill the splash pan with approximately 2"-3" warm water. Gently place both steamer pans (Item 3) into the splash pan.

**Step 4.** Fit can support (Item 1) into the slots in the drawer (see Fig. 2). **Ensure it is secure.**

**Step 5.** Removing the lids, place the two supplied chafing dish fuel cans (Item 2) into the can support.

**Important: DO NOT BURN CHAFING DISH FUEL WITH DRAWER OPEN.**

**Step 7.** Place desired food to be warmed in the steamer pans & fit the lids (Item 4).

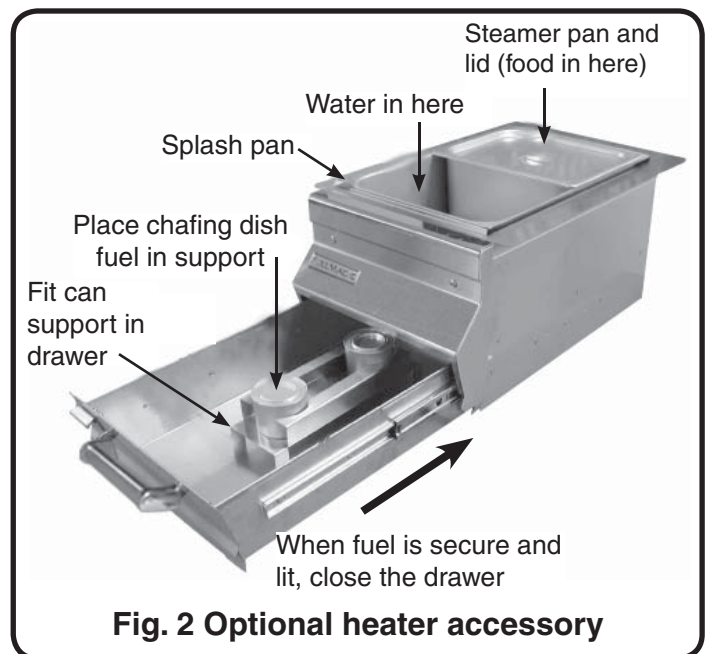

**Fig. 2 Optional heater accessory**

**CAUTION:** The water in the splash pan will get hot and is a scald and burn hazard.

**Do not attempt to empty it until it is cooled.**

**TO EXTINGUISH** the chafing dish flame, open drawer & carefully replace fuel lid; flames will go out.

**Note:** For any subsequent uses, always read and follow safety warnings & lighting instructions supplied with the fuel.

**CAUTION: BURN HAZARD**

**During & immediately after use the chafing dishes will be hot. Do not handle until cold.**

**Important: DO NOT LEAVE CHAFING DISHES BURNING UNATTENDED.**

**Do not leave children unattended around the bar caddy during & immediately after use.**

**To reuse as a drink and condiment cooler, remove the can support from the drawer and remove the steamer pans and lids from the splash pan. Remove the splash pan. Replace the insulation, splash pan, caddy top, cover, and condiment/bottle holders. Fill the splash pan with ice.**