



Tempest™ Wall Mount

(sku 94800825)

Overview

- Tempest Torch 24v (SKU 94900745 NG, 94900755 LP)
- Tempest Torch 120v (SKU 94900744 NG, 94900754 LP) *
- Tempest Torch Manual (SKU 94900743 NG, 94900753 LP) **

* This torch will work with the wall mount. Follow the instructions in the manual for attaching the electrical line.

** This torch will work with the wall mount. Disregard instructions in these instructions regarding the electrical line.

Packing List

- Control Cover (a)
- Post (b)
- Wall Plate Cover (c)
- Wall Plate with Post Bracket (d)
- Rough-in Template (e)

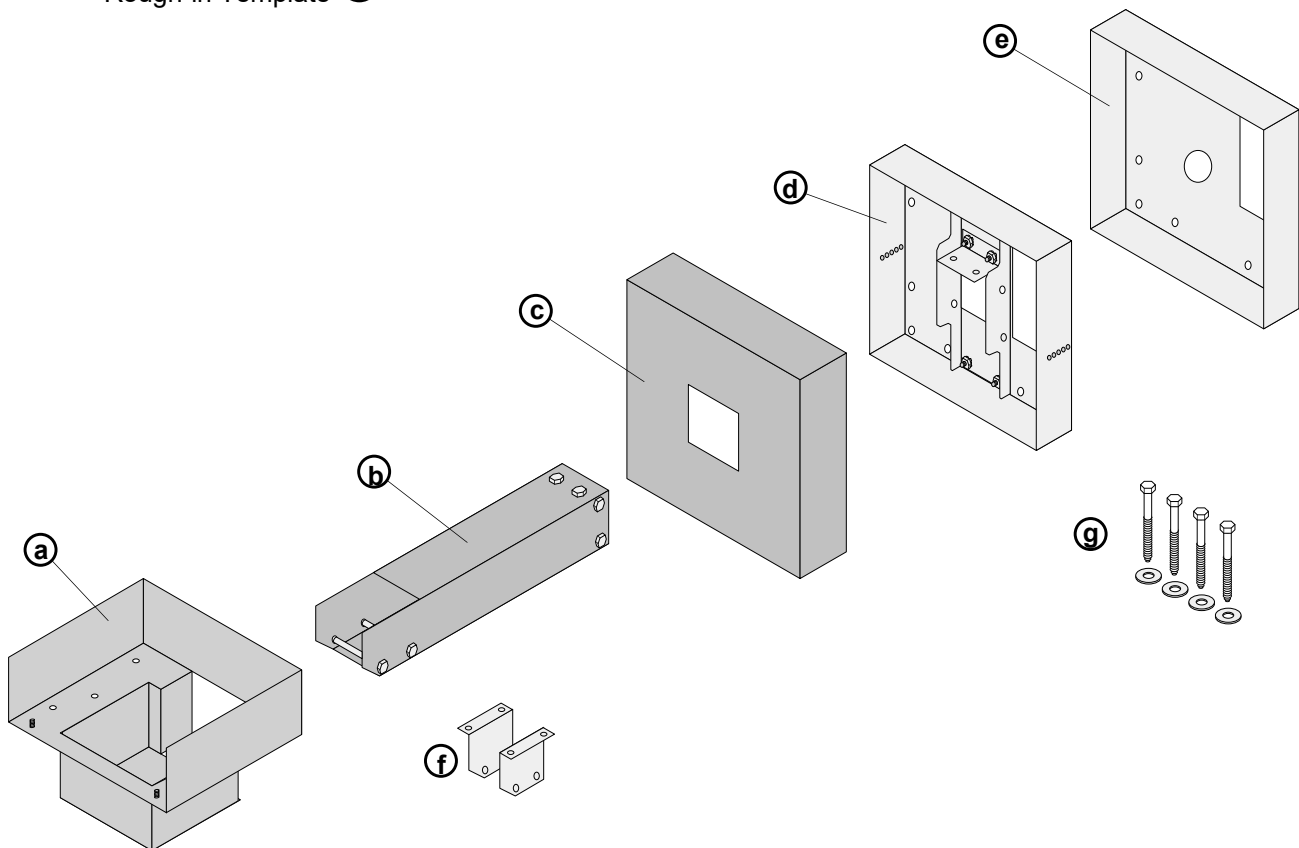

Hardware Pack Components

- (4) 2-1/2" Stainless Steel Lag Bolts and Washers (g)
- Head Mounting Brackets (f)
- 1/2" FPT to 1/2" MPT Elbow
- Shutoff Valve - 1/2" FPT to 3/8" Flare
- 3/8" x 16" Stainless Flex Tubing
- 3/8" to 3/8" Tubing Connector



Tempest™ Wall Mount

(sku 94800825)

Torch Location – Clearance to Combustibles

The wall mount must be properly positioned to provide proper clearance to combustibles when the torch is attached. See the illustration below for details.

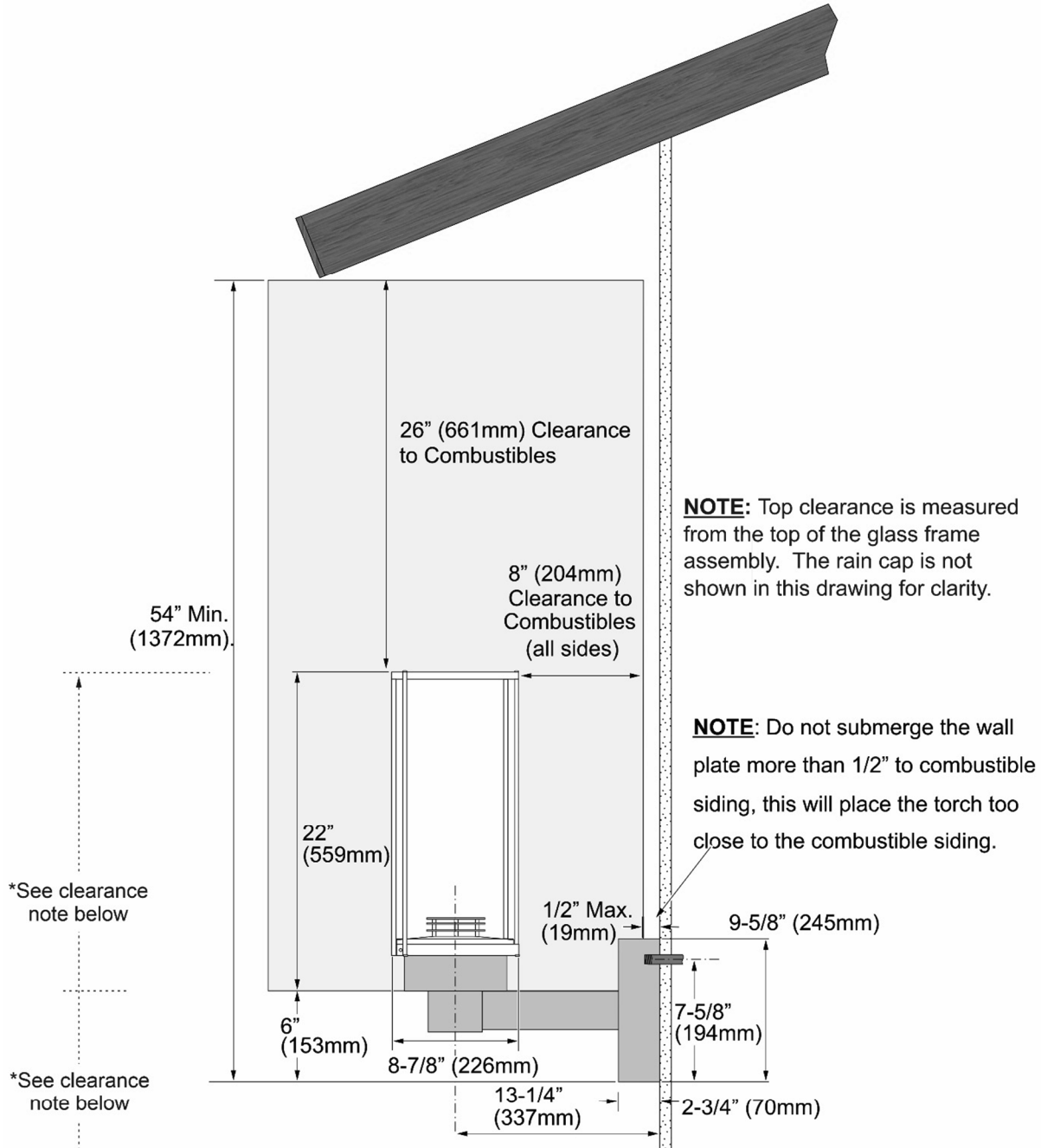

NOTE: Top clearance is measured from the top of the glass frame assembly. The rain cap is not shown in this drawing for clarity.

NOTE: Do not submerge the wall plate more than 1/2" to combustible siding, this will place the torch too close to the combustible siding.

***NOTE:** The distance from ground level to the top of the Torch shall be a minimum of 7' (2.1m) where installed within 2' (0.6M) of public walkways (e.g.: sidewalk, shared walkway between two homes, or pathway in commercial applications). Lesser clearances shall be permitted to be used only where acceptable to the authority having jurisdiction.

63" - Minimum height above grade the top of the post must be above grade to meet this requirement.



Tempest™ Wall Mount

(sku 94800825)

Gas Line Location and Wall Plate Placement

The gas line must be located correctly to allow proper placement of the shutoff valve under the wall plate cover. See the illustration below for details.

SIDE VIEW

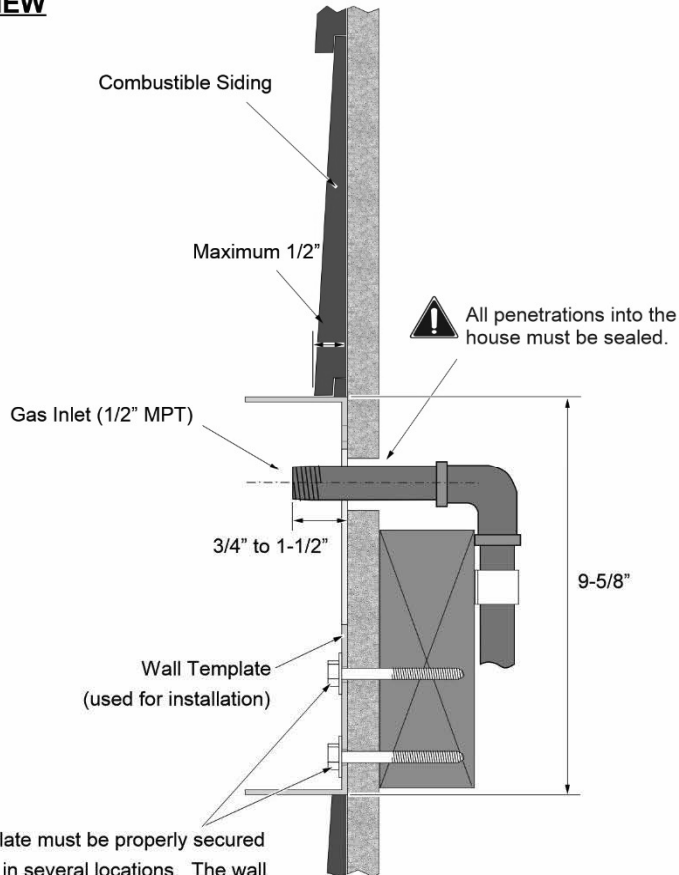

The wall plate must be properly secured to framing in several locations. The wall mount, with torch, weighs approximately 25 lbs and must be properly supported.

FRONT VIEW

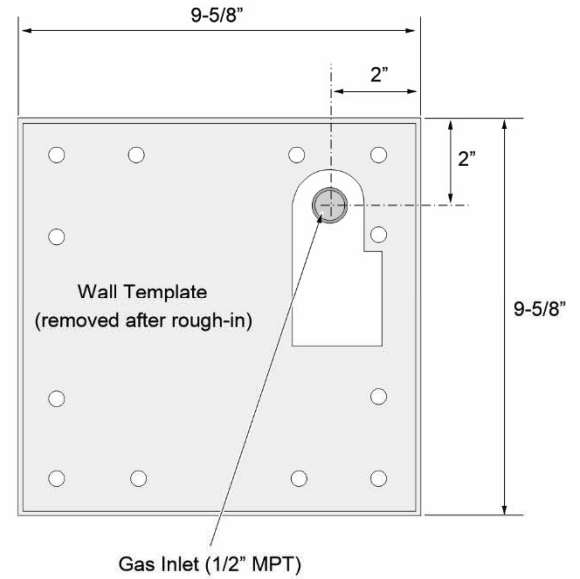



TRAVIS INDUSTRIES
HOUSE OF FIRE

Tempest™ Wall Mount

(sku 94800825)

Installation

NOTE: The illustrations below are for example only. Make sure to follow all gas line and building code requirements for your location.

1. Make sure adequate framing is provided behind the wall to support the weight of the torch. Install the wall plate template in the desired location using the (4) included lag bolts. This template will help locate where the gas line and electrical will penetrate the wall (see Figure 1).

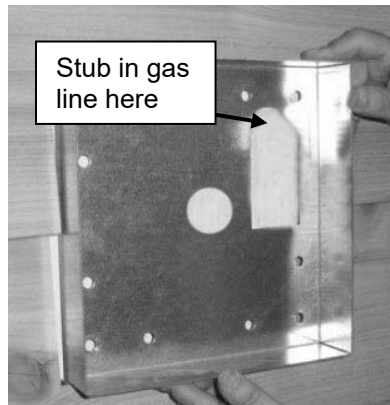

Figure 1

2. Run the gas line to the correct location (see the illustration figure 3 details). Make sure the gas nipple protrudes between $\frac{3}{4}$ " and 1-1/2"

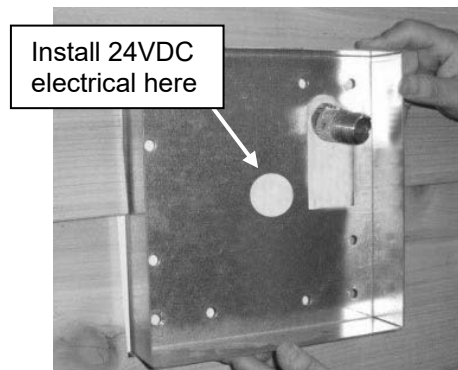

Figure 2



TRAVIS INDUSTRIES
HOUSE OF FIRE

Tempest™ Wall Mount

(sku 94800825)

3. Attach the included elbow and shutoff valve to the nipple (use thread sealant, etc.). Make sure the elbow is facing directly down and the shutoff valve is facing outwards as shown in Figure 3. Run the electrical line (if applicable) through the center hole of the wall plate and leave at least 14" of wire forward of the wall plate.

NOTE: You may wish to pressure-test the gas line at this time.

NOTE: If you are doing this installation in two stages, you can now mask off the front of the template box and finish material can be applied to the wall surface around the mount. You will remove the template and replace it with the wall plate when the site is ready for final installation.



Figure 3

4. Place the wall plate on a suitable work surface and remove the (4) nuts (and washers) that hold the post bracket in place (see Figure 4). Remove the post bracket (see Figure 5).



Figure 4

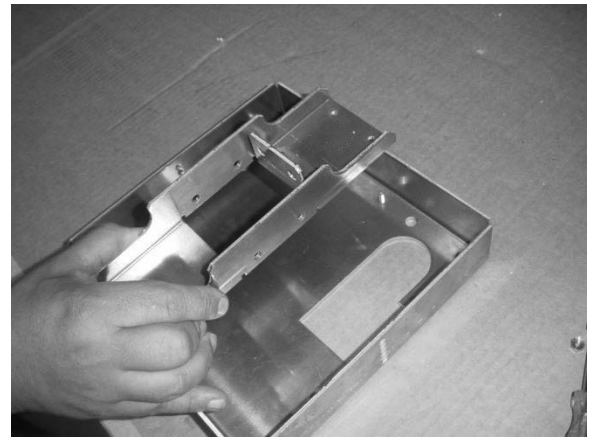

Figure 5



TRAVIS INDUSTRIES
HOUSE OF FIRE

Tempest™ Wall Mount

(sku 94800825)

5. Remove and discard the templet used in step 3 (set the (4) lag bolts aside for reinstallation). Place a ¼" bead of silicone around the perimeter of the wall plate location (see Figure 6). This silicone will help weatherize the wall mount. **Seal the gas line and electrical penetrations and any exposed exterior sheeting at this time.** Secure the wall plate to the wall using the four lag bolts used to secure the templet in step 3 (see Figure 7) or other suitable means. Once the wall plate is in place, you may wish to seal the area around the perimeter of the wall plate if it is exposed to weather (see Figure 8). Make sure the sealant does not interfere with the cover plate – wipe off any excess sealant before proceeding.

WARNING: Seal the penetrations for the electrical and gas lines. Negative pressure in the building can cause heat failure components.

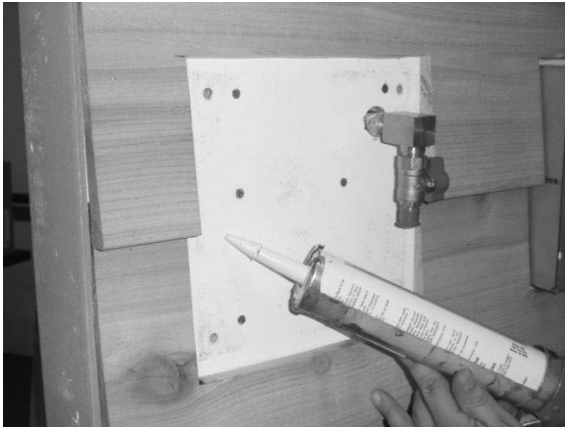

Figure 6

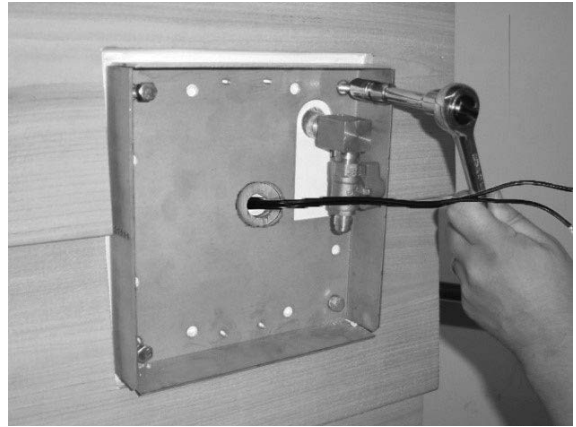

Figure 7

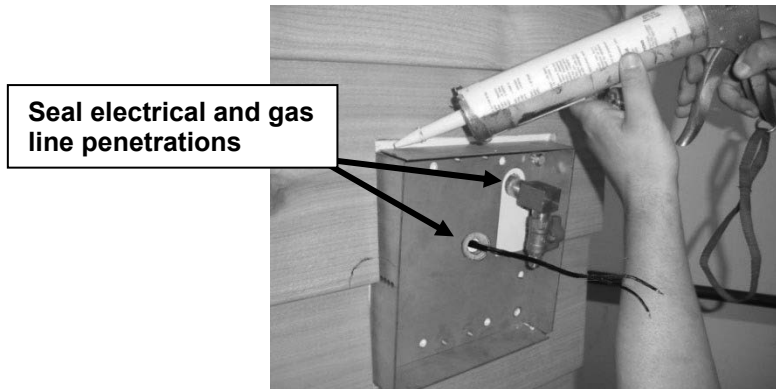

Figure 8



TRAVIS INDUSTRIES
HOUSE OF FIRE

Tempest™ Wall Mount

(sku 94800825)

6. Remove the control cover and mounting bracket on the bottom of the tempest torch head (see Figure 9). Keep the screws and nuts. Remove the hinged control cover from the front of the stock cover and install it on the cover included with the wall mount kit.

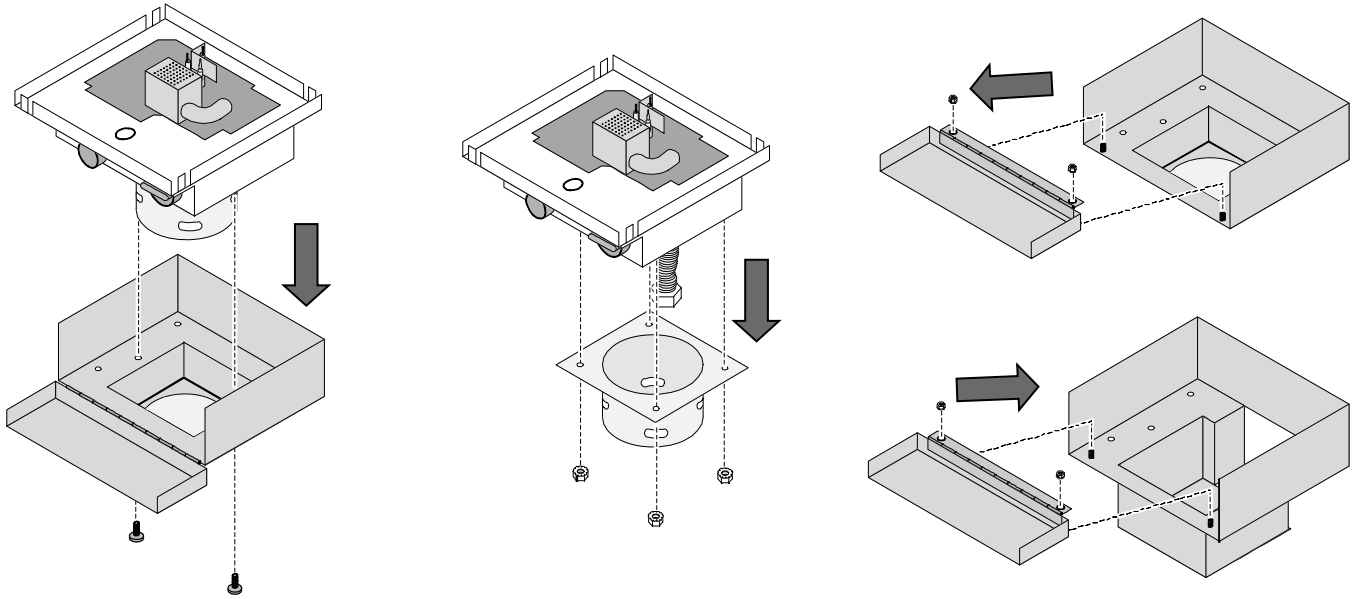

Figure 9

7. Install the Head Mounting Brackets (included in the hardware pack) to the bottom of the torch head. The tabs should be oriented toward the sides of the torch head and lopped-off corners should be facing the front of the torch (see figure 10). Use the nuts that were removed in step (6).

- Tab faces out
- Lopped edge faces forward

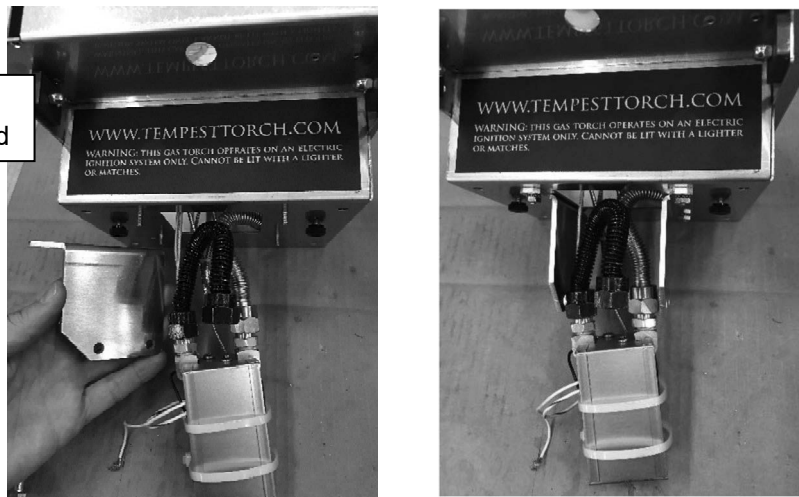

Figure 10



TRAVIS INDUSTRIES
HOUSE OF FIRE

Tempest™ Wall Mount

(sku 94800825)

- Place the post on a suitable work surface and remove the (2) through-bolts (with washers and nuts) and the (2) bolts (with washers) from the threaded holes on the top of the post. Use the (2) through-bolts (with washers and nuts) to secure the post bracket to the post (see Figure 11). Attach the (2) top bolts through the leveling bracket (pre-installed on the post bracket) into the post – **DO NOT OVERTIGHTEN THESE BOLTS – THEY THREAD INTO THE ALUMINUM POST** (see Figure 12)

Remove the (2) through-bolts and (2) top bolts

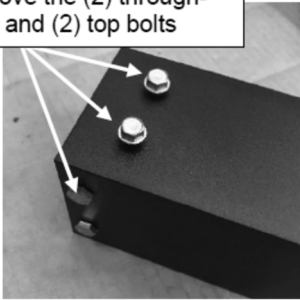

Figure 11

- Guide the electrical wire through the post. Position the post assembly over the wall plate and line up the holes in the post bracket with the studs on the wall plate (see below). Attach the post with the four nuts (and washers) removed in step 4.

NOTE: You may wish to level and square the wall mount if the post does not appear correct. Washers may be placed between the post bracket and wall plate to shim the post to the correct position.





Tempest™ Wall Mount

(sku 94800825)

10. Slide the wall plate cover (Figure 12 – **make sure it is positioned correctly – the circular indents are on the sides**), and control cover over the post (Figure 13).



Figure 12



Figure 13

11. Attach the flex tube and fitting to the gas inlet on the torch (use adapter included in the hardware pack. See figure 14). Route the flex tube and the gas control assembly so it angles back and slightly downward. Insert the gas line and control assembly through the post. Push the gas line through to the mounting plate (see Figure 14, 15 & 16). Grasp the end of the flex tube and pull it through as you position the head mounting brackets over the outside end of the post and line up the holes in the head mounting brackets with the holes in the mounting post (see Figure 16). Attach the torch to the post using the through-bolts removed in step 9 (see Figure 17).



Figure 14



Figure 15

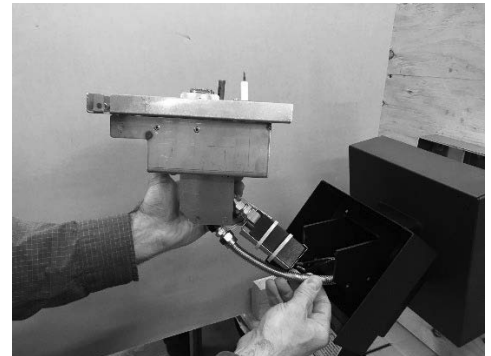

Figure 16

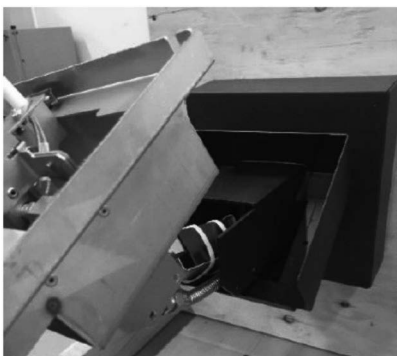

Figure 17



Figure 18

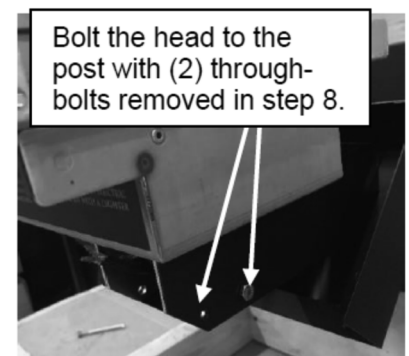

Figure 19



TRAVIS INDUSTRIES
HOUSE OF FIRE

Tempest™ Wall Mount

(sku 94800825)

12. Route flex tube from the post to the shutoff valve (see Figure 20). Attach the flex tube to the shutoff valve (see Figure 21). At this time you should turn on the gas to the torch, purge the gas line, and leak test the gas line connections.



Figure 20



Figure 21

13. Connect the electrical supply wires to the two wires from the control module assembly with wire nuts (see torch manual for wiring details).



14. Attach the control cover to the torch using the thumbscrews removed in step 9 (see Figure 22).

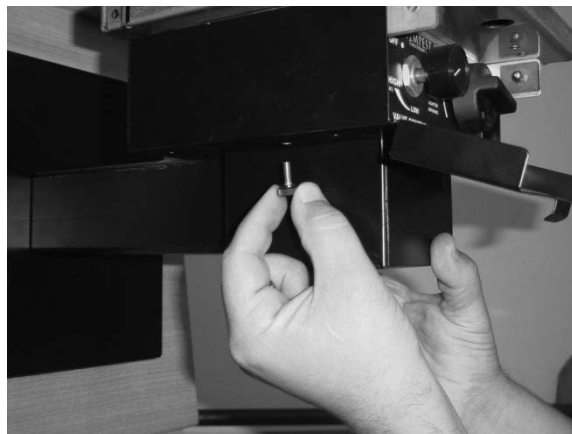

Figure 22

15. Complete assembly of the torch (see the owner's manual for details).