



# Tempest™ 50k Lantern Wall Mount

(sku 94800832)

## Overview

- Tempest Lantern 50k - SKU 94900748

## Packing List

- Control Cover (a)
- Post (b)
- Wall Plate Cover (c)
- Wall Plate with Post Bracket (d)
- Rough-in Template (e)
- Head Mounting Brackets (f)

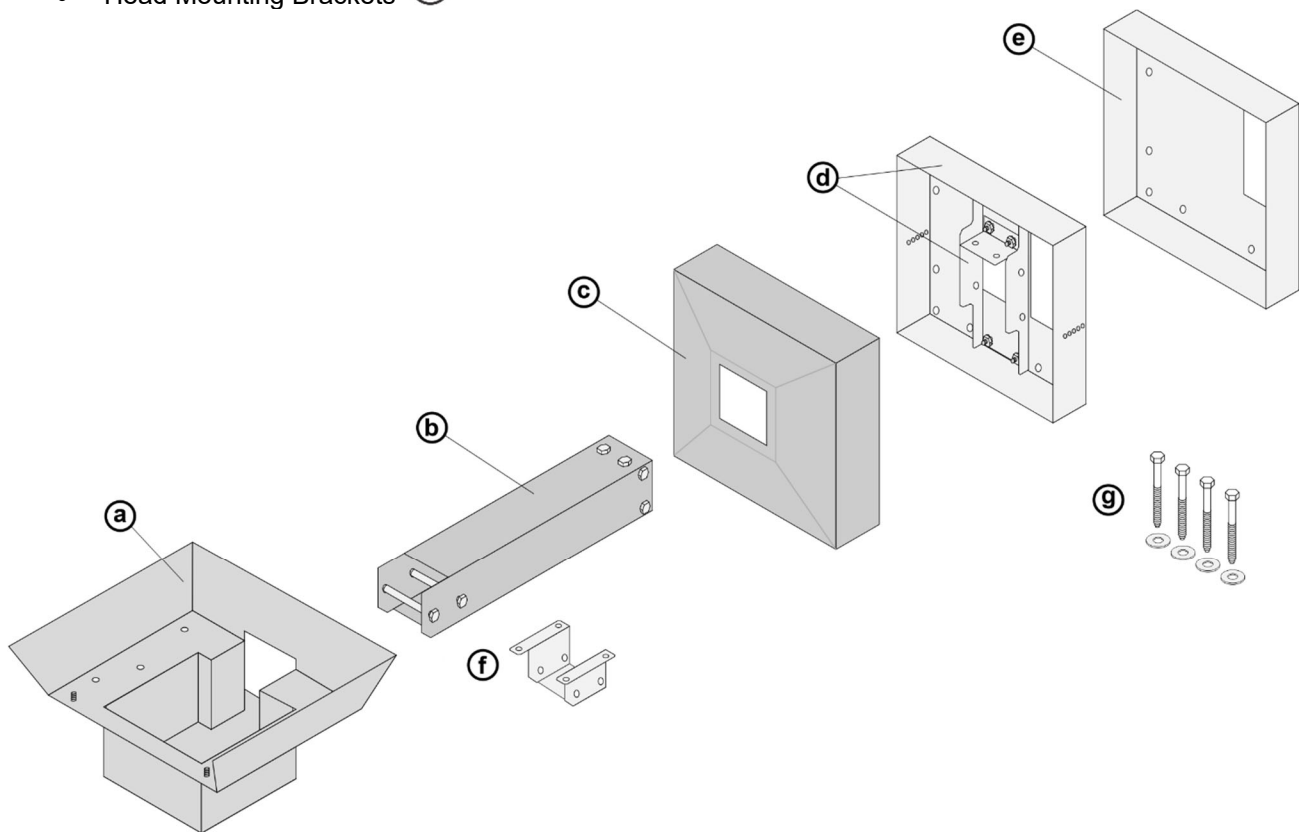

## Hardware Pack Components

- (4) 2-1/2" Stainless Steel Lag Bolts and Washers (g)
- 1/2" FPT to 1/2" MPT Elbow
- Shutoff Valve - 1/2" FPT to 3/8" Flare
- 3/8" x 16" Stainless Flex Tubing
- 3/8" to 3/8" Tubing Connector



# Tempest™ 50k Lantern Wall Mount

(sku 94800832)

## Lantern Location – Clearance to Combustibles

The wall mount must be properly positioned to provide proper clearance to combustibles when the lantern is attached. See the illustration below for details.

**NOTE:** If the siding is thicker than 1" (26mm) add material behind the lantern mount so the base is not submerged more than 1" (26mm) into the siding.

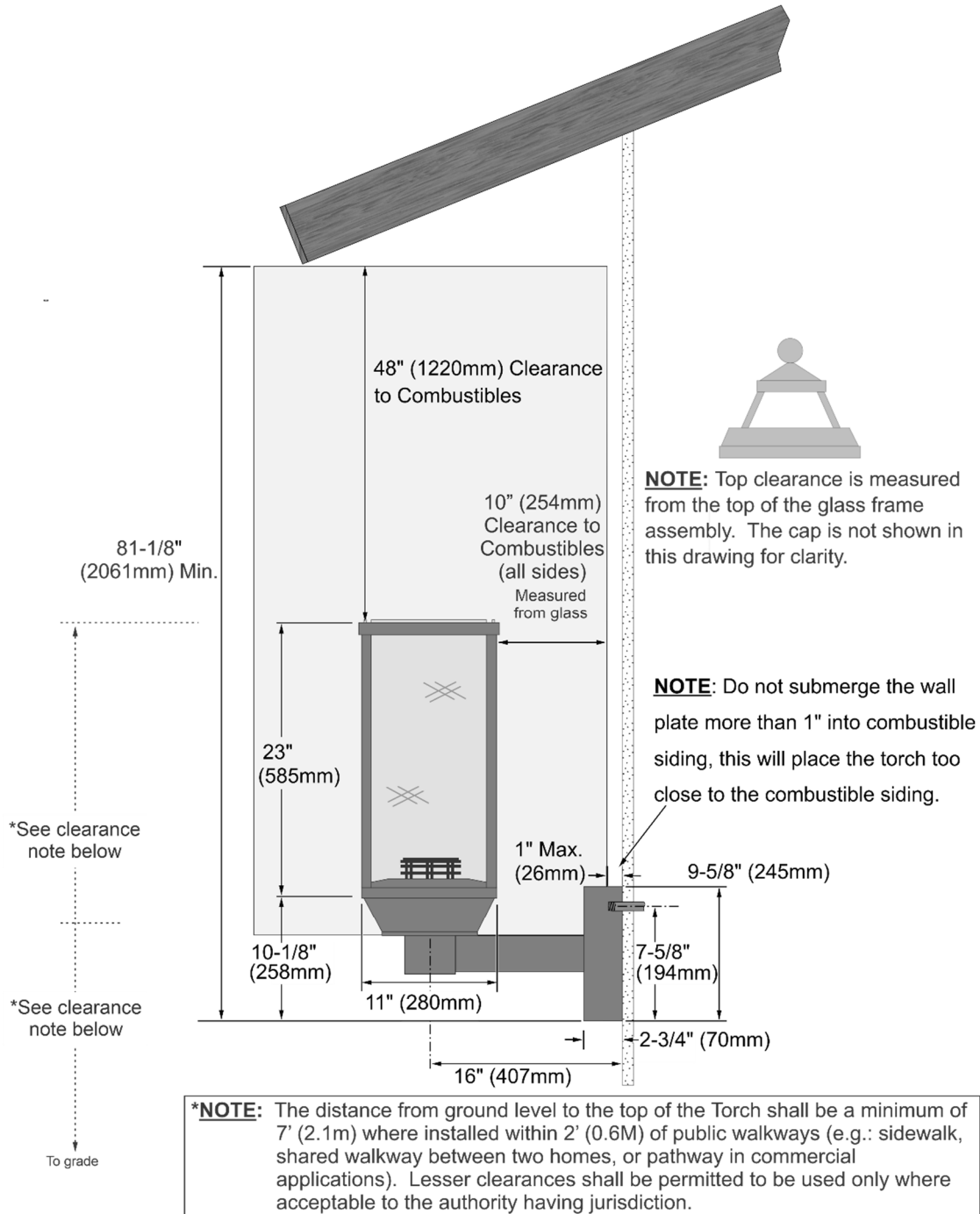



# Tempest™ 50k Lantern Wall Mount

(sku 94800832)

## Gas Line Location and Wall Plate Placement

The gas line must be located correctly to allow proper placement of the shutoff valve under the wall plate cover. See the illustration below for details.

### SIDE VIEW

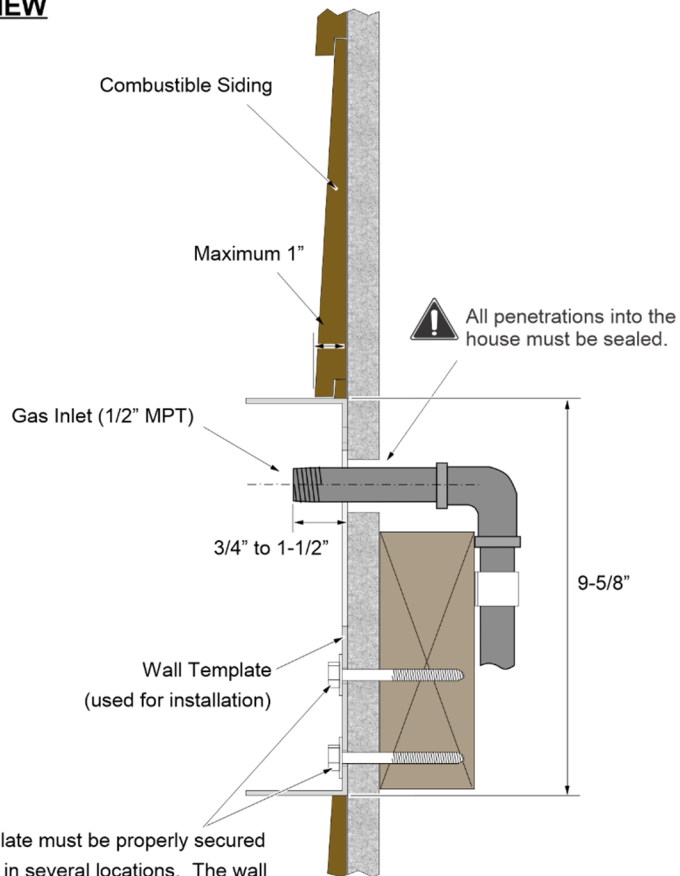

The wall plate must be properly secured to framing in several locations. The wall mount, with torch, weighs approximately 30 lbs and must be properly supported.

### FRONT VIEW

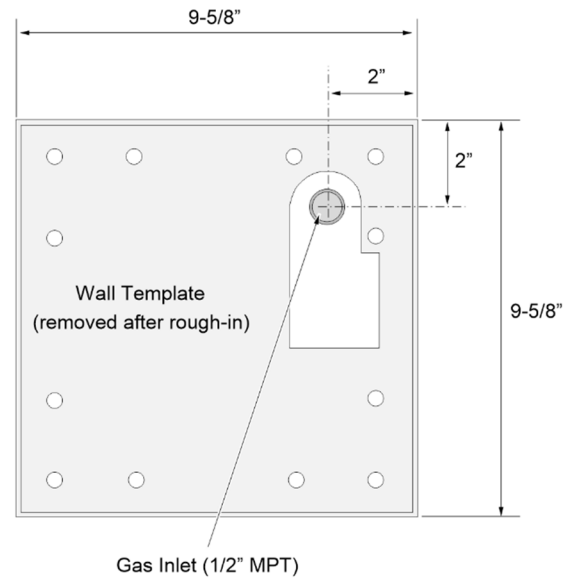



# Tempest™ 50k Lantern Wall Mount

(sku 94800832)

## **Installation**

**NOTE:** The illustrations below are for example only. Make sure to follow all gas line and building code requirements for your location.

1. Make sure adequate framing is provided behind the wall to support the weight of the lantern. Install the wall plate template in the desired location using the (4) included lag bolts. This template will help locate where the gas line and electrical will penetrate the wall (see Figure 1).

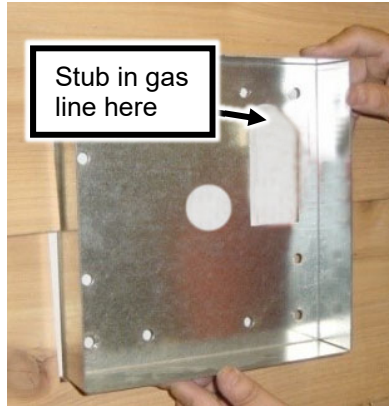

Figure 1

2. Run the gas line to the correct location (see the illustration figure 3 details). Make sure the gas nipple protrudes between  $\frac{3}{4}$ " and 1-1/2"



Figure 2



## Tempest™ 50k Lantern Wall Mount

(sku 94800832)

3. Attach the included elbow and shutoff valve to the nipple (use thread sealant, etc.). Make sure the elbow is facing directly down and the shutoff valve is facing outwards as shown in Figure 3. Run the electrical line (if applicable) through the center hole of the wall plate and leave at least 14" of wire forward of the wall plate.

**NOTE:** You may wish to pressure-test the gas line at this time.

**NOTE:** If you are doing this installation in two stages, you can now mask off the front of the template box and finish material can be applied to the wall surface around the mount. You will remove the template and replace it with the wall plate when the site is ready for final installation.



Figure 3

4. Place the wall plate on a suitable work surface and remove the (4) nuts (and washers) that hold the post bracket in place (see Figure 4). Remove the post bracket (see Figure 5).

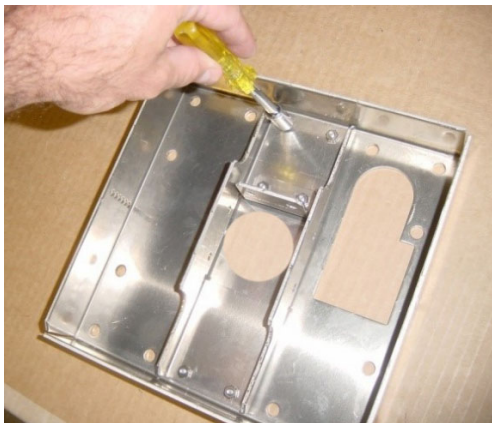

Figure 4



Figure 5



# Tempest™ 50k Lantern Wall Mount

(sku 94800832)

5. Remove and discard the templet used in step 3 (set the (4) lag bolts aside for reinstallation). Place a ¼" bead of silicone around the perimeter of the wall plate location (see Figure 6). This silicone will help weatherize the wall mount. **Seal the gas line and electrical penetrations and any exposed exterior sheeting at this time.** Secure the wall plate to the wall using the four lag bolts used to secure the templet in step 3 (see Figure 7) or other suitable means. Once the wall plate is in place, you may wish to seal the area around the perimeter of the wall plate if it is exposed to weather (see Figure 8). Make sure the sealant does not interfere with the cover plate – wipe off any excess sealant before proceeding.

**WARNING: Seal the penetrations for the electrical and gas lines. Negative pressure in the building can cause heat failure of components.**



Figure 6



Figure 7

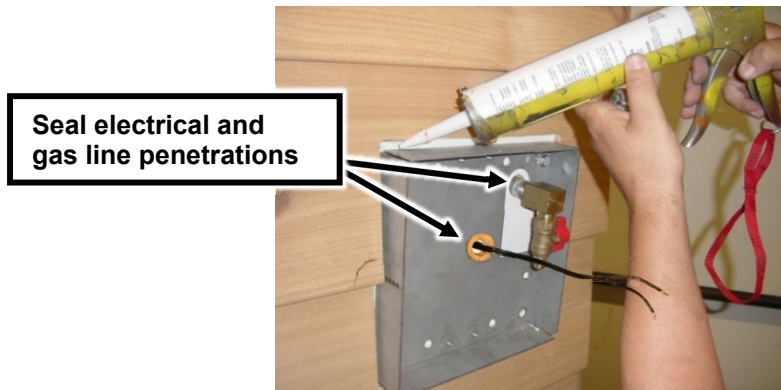

Figure 8



# Tempest™ 50k Lantern Wall Mount

(sku 94800832)

6. With the rain cap off and no glass installed, turn the lantern upside down and place it on a soft surface to protect the finish.

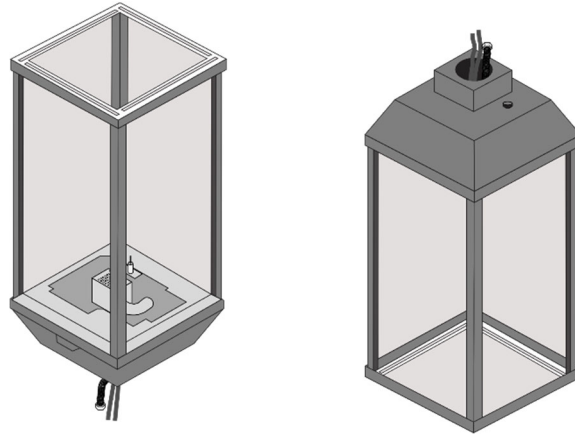

7. Remove the (2) thumb screws that secure the bottom cover to the lantern (set aside for reinstallation). Carefully remove the bottom cover from the lantern, make sure not to damage any gas or electrical components.

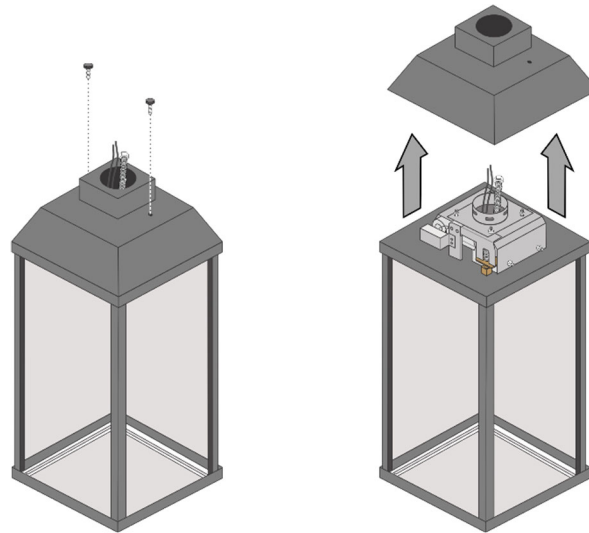

8. Remove the hinged control cover from the front of the stock cover and install it on the cover included with the wall mount kit.

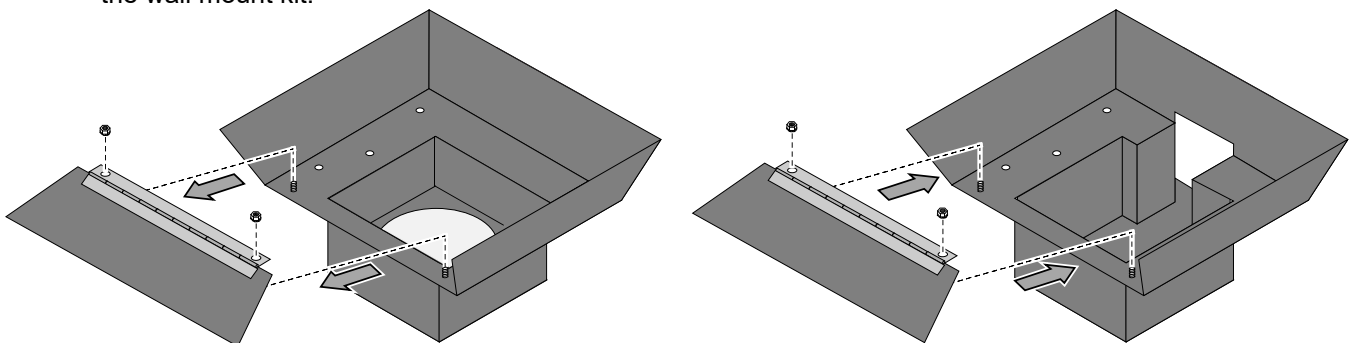



# Tempest™ 50k Lantern Wall Mount

(sku 94800832)

9. Use an 11/32" nut driver to remove the (4) nuts that secure the mounting collar to the lantern. Carefully remove the mounting collar from the lantern base, make sure not to damage any gas or electrical components. Discard the collar. Keep the nuts for reinstallation.

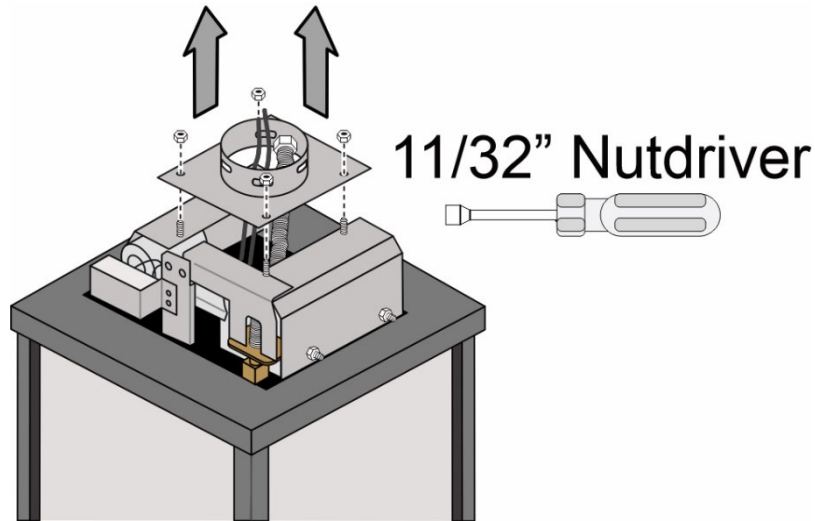

10. Install the wall mount brackets onto the lantern base. Make sure the brackets are oriented properly. The lopped corners should face the front of the lantern (see illustration below). Use the nuts removed in the previous step to secure the bracket to the base.

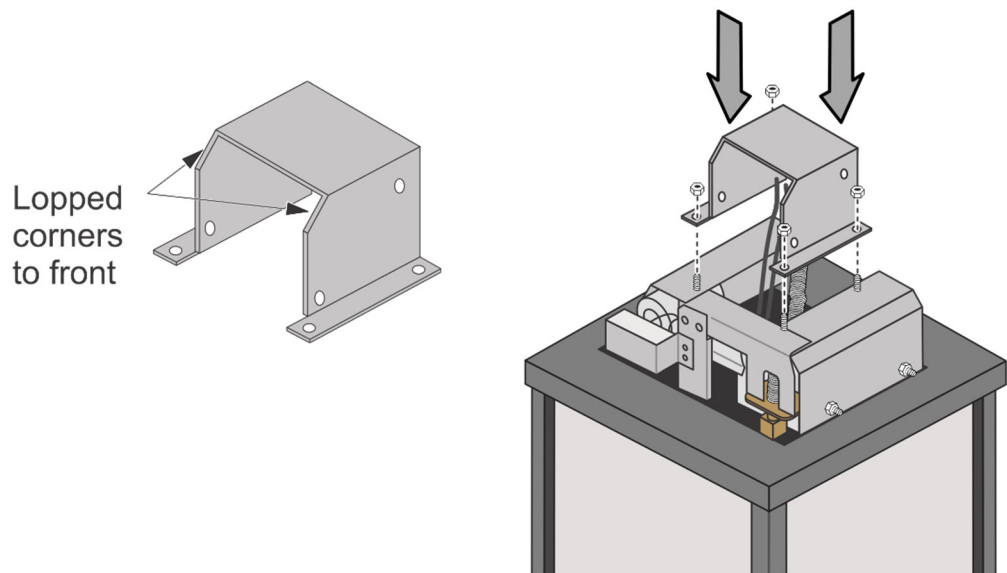





# Tempest™ 50k Lantern Wall Mount

(sku 94800832)

11. Place the post on a suitable work surface and remove the (2) through-bolts (with washers and nuts) and the (2) bolts (with washers) from the threaded holes on the top of the post. Use the (2) through-bolts (with washers and nuts) to secure the post bracket to the post (see Figure 11). Attach the (2) top bolts through the leveling bracket (pre-installed on the post bracket) into the post – **DO NOT OVERTIGHTEN THESE BOLTS – THEY THREAD INTO THE ALUMINUM POST** (see Figure 12)



Figure 11

12. Guide the electrical wire through the post. Position the post assembly over the wall plate and line up the holes in the post bracket with the studs on the wall plate (see below). Attach the post with the four nuts (and washers) removed in step 4.

**NOTE:** You may wish to level and square the wall mount if the post does not appear correct. Washers may be placed between the post bracket and wall plate to shim the post to the correct position.





# Tempest™ 50k Lantern Wall Mount

(sku 94800832)

- Slide the wall plate cover (Figure 12 – **make sure it is positioned correctly – the circular indents are on the sides**), and control cover over the post (Figure 13). Leave the cover loose so gas connections can be made

**NOTE:** The images below show the Tempest Torch version of the wall plate cover. The Tempest Lantern version has a tapered appearance but attaches in the same way.



Figure 12



Figure 13

- Attach the flex tube and fitting to the gas inlet on the lantern (use adapter included in the hardware pack. See figure 14). Route the flex tube and the gas control assembly so it angles back and slightly downward. Insert the gas line and control assembly through the post. Push the gas line through to the mounting plate (see Figure 14,15 & 16). Grasp the end of the flex tube and pull it through as you position the head mounting brackets over the outside end of the post and line up the holes in the head mounting brackets with the holes in the mounting post (see Figure 17 &18). Attach the lantern to the post using the through-bolts removed in step 8 (see Figure 19).



Figure 14



Figure 15



Figure 16



Figure 17



Figure 18



Figure 19

15. Route flex tube from the post to the shutoff valve (see Figure 20). Attach the flex tube to the shutoff valve (see Figure 21). At this time you should turn on the gas to the lantern, purge the gas line, and leak test the gas line connections.



Figure 20



Figure 21

16. Connect the electrical supply wires to the two wires from the control module assembly with wire nuts (see lantern manual for wiring details). Slide the wall mount cover into place.



17. Attach the control cover to the lantern using the thumbscrews removed in step 9 (see Figure 22).

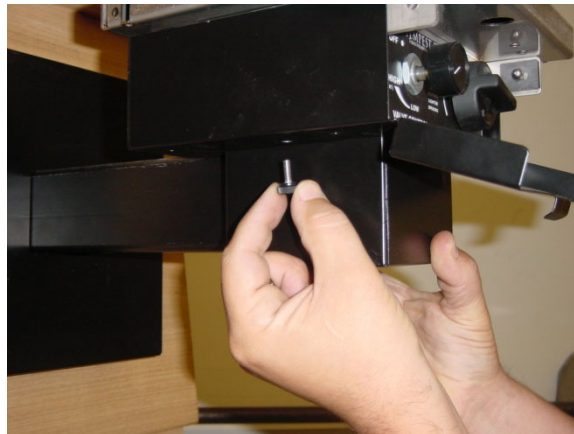

Figure 22

18. Complete assembly of the lantern (see the owner's manual for details).